

# CONTENTS

<b>Chapter 1 Safety Information and Precautions</b> .....	<b>- 1 -</b>
1.1 Electrical Safety .....	- 1 -
1.2 Machine/System Design and Safety of Personnel .....	- 1 -
1.3 Working Environment and Handling .....	- 1 -
1.4 Electrical Installation - Safety .....	- 1 -
1.5 AC Motor (Induction/Asynchronous) .....	- 2 -
1.6 Adjusting AC Drive Parameters .....	- 2 -
<b>Chapter 2 Product Information</b> .....	<b>- 4 -</b>
2.1 Naming Rules .....	- 4 -
2.2 Nameplate .....	- 4 -
2.3 Information of Product Model .....	- 5 -
2.4 Appearance, Mounting Dimensions .....	- 8 -
2.5 External Dimensions of Control Panel .....	- 11 -
2.6 External Dimensions of Control Panel Bracket .....	- 12 -
2.7 Guide to Select Brake Components .....	- 13 -
<b>Chapter 3 Installation and Wiring</b> .....	<b>- 14 -</b>
3.1 Installation Environment .....	- 14 -
3.2 Minimum Mounting Clearances .....	- 14 -
3.3 Remove & Mount Control Panel and Cover .....	- 15 -
3.4 Wiring Diagram .....	- 17 -
3.5 Control Terminal Specification .....	- 18 -
<b>Chapter 4 Operation and Run Instructions</b> .....	<b>- 27 -</b>
4.1 Operation of Control Panel .....	- 27 -
4.2 Quick setup .....	- 29 -
<b>Chapter 5 List of Parameters</b> .....	<b>- 30 -</b>
5.1 Fundamental group of parameters .....	- 30 -
5.2 DI function selection .....	- 66 -
5.3 DO function selection .....	- 67 -
<b>Chapter 6 Trouble Shooting</b> .....	<b>- 68 -</b>
6.1 Faults and Solutions .....	- 68 -
6.2 Common Symptoms and Diagnostics .....	- 73 -
<b>Chapter 7 Maintenance</b> .....	<b>- 74 -</b>
7.1 Daily inspection .....	- 74 -
7.2 Regular Maintenance .....	- 75 -
7.3 Replacement of Vulnerable Parts .....	- 76 -
7.4 Storage .....	- 76 -
<b>Appendix: Modbus Communication Protocol</b> .....	<b>- 77 -</b>



# Chapter 1 Safety Information and Precautions

## 1.1 Electrical Safety

Extreme care must be taken at all times when working with the AC Drive or within the area of the AC Drive. The voltages used in the AC Drive can cause severe electrical shock or burns and is potentially lethal. Only authorized and qualified personnel should be allowed to work on AC Drives.

## 1.2 Machine/System Design and Safety of Personnel

- Machine/system design, installation, commissioning startups and maintenance must be carried out by personnel who have the necessary training and experience. They must read this safety information and the contents of this manual. If incorrectly installed, the AC Drive may present a safety hazard.
- The AC Drive uses high voltages and currents (including DC), carries a high level of stored electrical energy in the DC bus capacitors even after power OFF. These high voltages are potentially lethal.
- The AC Drive is NOT intended to be used for safety related applications/functions. The electronic "STOP & START" control circuits within the AC Drive must not be relied upon for the safety of personnel. Such control circuits do not isolate mains power voltages from the output of the AC Drive. The mains power supply must be disconnected by a electrical safety isolation device before accessing the internal parts of the AC Drive.
- Safety risk assessments of the machine or process system which uses an AC Drive must be undertaken by the user and or by their systems integrator/designer. In particular the safety assessment/design must take into consideration the consequences of the AC Drive failing or tripping out during normal operation and whether this leads to a safe stop position without damaging machine, adjacent equipment and machine operators/users. This responsibility lies with the user or their machine/process system integrator.
- The system integrator/designer must ensure the complete system is safe and designed according to the relevant safety standards. Authorized Distributors can provide recommendations related to the AC drive to ensure long term safe operation.

## 1.3 Working Environment and Handling

- Matters related to transport, storage, installation, IP rating, working environment and AC Drive tolerance limits (temperature, ambient, voltage, pollution, vibration etc) can be found within this manual. The guidelines and recommendations should be followed in order to gain long term trouble free operation as the lifetime of the AC Drive is dependent on the working environment and correct handling of the product in the initial installation stage.

## 1.4 Electrical Installation - Safety

- Electrical shock risk is always present within an AC Drive including the output cable leading to the motor terminals. Where dynamic brake resistors are fitted external to the AC Drive, care must be taken with regards to live contact with the brake resistors, terminals which are at high DC voltage and potentially lethal. Cables from the AC Drive to the dynamic brake resistors should be double insulated as DC voltages are typically 600 to 700 VDC.

- Mains power supply isolation switch should be fitted to the AC Drive. The mains power supply must be disconnected via the isolation switch before any cover of the AC Drive can be removed or before any servicing work is undertaken.
- Stored charge in the DC bus capacitors of the PWM AC Drive is potentially lethal after the AC supply has been disconnected. The AC supply must be isolated at least 10 minutes before any work can be undertaken as the stored charge will have been discharged through the internal bleed resistor fitted across the DC bus capacitors.
- Whenever possible, it is good practice to check the DC bus voltage with a VDC meter before accessing the AC Drive bridge. Where the AC Drive input is connected to the mains supply with a plug and socket, then upon disconnecting the plug and socket, be aware that the plug pins may be exposed and internally connected to the DC bus capacitors (via the internal bridge rectifier in reversed bias). Wait 10 minutes to allow stored charge in the DC bus capacitors to be dissipated by the bleed resistors before commencing work on the AC Drive.
- When using an earth leakage circuit breaker, use a residual current operated protective device (RCD) of type B (breaker which can detect both AC and DC). Leakage current can cause unprotected components to operate incorrectly. If this is a problem, lower the carrier frequency, replace the components in question with parts protected against harmonic current, or increase the sensitivity amperage of the leakage breaker to at least 200 mA per drive.

Factors in determining leakage current:

- Size of the AC drive
- AC drive carrier frequency
- Motor cable type and length
- EMI/RFI filter

For more information, contact us.

### 1.5 AC Motor (Induction/Asynchronous)

- AC induction motors are designed to run at fixed speed at the 50 or 60 Hz supply frequency and therefore it's cooling capability is dependent on the axial driven fan mounted at the non drive end.
- When the motor is operated at variable speed with the AC Drive, it is necessary to consider the reduced cooling rate especially when running at low speed for considerable period of time. Please consult with the motor manufacturer who can provide cooling solutions such as a electric force ventilated fan or an "AC Drive" rated AC motor designed to handle reduced speed running with AC Drives.
- It is also necessary to consult with the motor manufacturer when above base speed (> 50/60 Hz) running is required and or when high speed operations are required. Motor suppliers also provide solutions for encoder feedback devices for close loop operation with an AC Drive.

### 1.6 Adjusting AC Drive Parameters

- The AC Drive when it leaves the factory with default settings should enable the user to get started quickly to check on the basic mechanical running conditions. At a later time, fine tuning to optimize the operation/ performance can be undertaken.
- Such parameter tuning should be done by qualified personnel who have prior training on AC Drives. Some parameter settings if manipulated incorrectly can have adverse reactions and

care should be taken especially during the commissioning startup stages to prevent personnel from engaging the machine.

- This manual provides a complete list of the parameters with functional description and care should always be taken whenever parameters are adjusted during a live running startup. Authorized Distributors can provide product training and if in doubt seek advice.

# Chapter 2 Product Information

## 2.1 Naming Rules

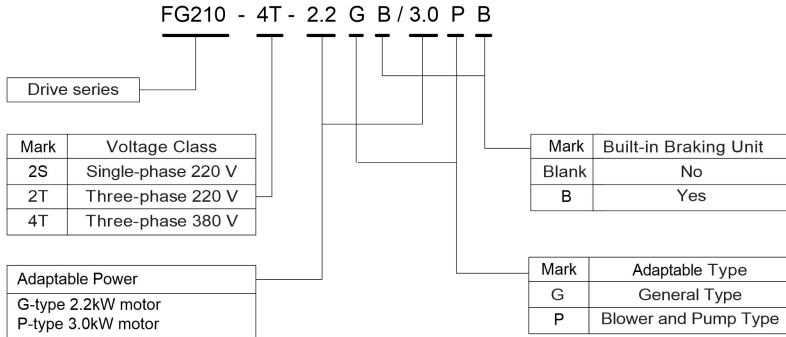

Fig.2.1-1 Naming Rules

## 2.2 Nameplate

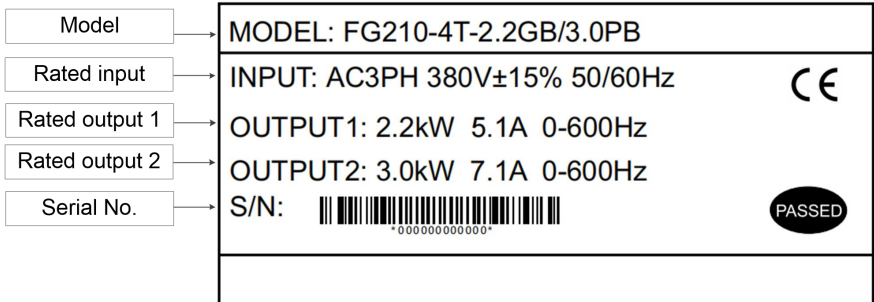

Fig. 2.2-1 Nameplate instructions

2.3 Information of Product Model

Table 2.3-1 Product model and technical data(three-phase 380V)

Model	Power rating (kW)	Output current (A)	Input current (A)	Matched motor (kW)	Brake unit
FG210-4T-0.4GB/0.75PB	0.4(0.75)	1.5(2.5)	1.9(3.5)	0.4(0.75)	Inbuilt
FG210-4T-0.75GB/1.5PB	0.75(1.5)	2.5(3.8)	3.5(4.6)	0.75(1.5)	
FG210-4T-1.5GB/2.2PB	1.5(2.2)	3.8(5.1)	4.6(6.3)	1.5(2.2)	
FG210-4T-2.2GB/3.0PB	2.2(3.0)	5.1(7.1)	6.3(8.6)	2.2(3.0)	
FG210-4T-4.0GB/5.5PB	4.0(5.5)	9.5(13)	12.1(16.8)	4.0(5.5)	
FG210-4T-5.5GB/7.5PB	5.5(7.5)	13(17)	16.8(22)	5.5(7.5)	
FG210-4T-7.5GB/11PB	7.5(11)	17(25)	22(32.5)	7.5(11)	
FG210-4T-11GB/15PB	11(15)	25(32)	32.5(41.5)	11(15)	
FG210-4T-15GB/18.5PB	15(18.5)	32(37)	41.5(49.6)	15(18.5)	
FG210-4T-18.5GB/22PB	18.5(22)	37(45)	49.6(59)	18.5(22)	
FG210-4T-22GB/30PB	22(30)	45(60)	59(65)	22(30)	

Table 2.3-2 Product model and technical data(three-phase 220V)

Model	Power rating (kW)	Output current (A)	Input current (A)	Matched motor (kW)	Brake unit
FG210-2T-0.4GB	0.4	2.3	4.0	0.4	Inbuilt
FG210-2T-0.75GB	0.75	4.0	4.8	0.75	
FG210-2T-1.5GB	1.5	7.0	8.8	1.5	
FG210-2T-2.2GB	2.2	9.6	12	2.2	

Table 2.3-3 Product model and technical data( single-phase 220V)

Model	Power rating (kW)	Output current (A)	Input current (A)	Matched motor (kW)	Brake unit
FG210-2S-0.4GB	0.4	2.3	5	0.4	Inbuilt
FG210-2S-0.75GB	0.75	4.0	8.2	0.75	
FG210-2S-1.5GB	1.5	7.0	14	1.5	
FG210-2S-2.2GB	2.2	9.6	23	2.2	

## 2.3.1 Technical Specification

Table 2.3-4 Technical Features of FG210

<b>Power input</b>	Rated input voltage	200V Voltage Class:single/three-phase 200V ~ 240V
		400V Voltage Class:Three-phase 380V~440V
	Frequency	50Hz/60Hz, tolerance $\pm 5\%$
	Voltage range	-15% ~ +15%
		Voltage out-of-balance rate < 3%, distortion rate as per the requirements of IEC61800-2
Rated input current	See Section 2.3	
<b>Power output</b>	Applicable motor (kW)	See Section 2.3
	Rated current (A)	See Section 2.3
	Output voltage (V)	3-phase:0% ~ rated input voltage, error < $\pm 3\%$
	Output frequency (Hz)	0.00% ~ 600.00Hz; unit:0.01Hz
	Overload capacity	G type:150% - 60 seconds, P type:120% - 60 seconds
<b>Control characteristics</b>	Control mode	V/f control Sensorless vector control (SVC)
	Range of speed regulation	1:200 (Sensor-less vector control )
	Speed accuracy	$\pm 0.5\%$ (Sensor-less vector control )
	Torque control accuracy	5%(SVC)
	Torque increase	Automatic torque lifting; Manual torque increased by 0.1-30.0%
	Starting torque	0.25Hz:150% (Sensor-less vector control )
<b>Basic functions</b>	Output frequency	0.00 ~ 600.00Hz
	ACC/DEC time	0.00 ~ 30000s
	Carrier frequency	0.5kHz ~ 16kHz
	Frequency setting	Digital setting + Keyboard Control Communication Analog setting Terminal pulse setting
	Motor start-up methods	Started from starting frequency DC brake start-up Speed tracking start
	Motor stop methods	Ramp to stop Free stop
	Dynamic braking capacity	Brake unit working voltage: 200V level:325-375V / 380V level:650V-810V Service time:0-100.0s;
	DC brake capacity	DC brake start frequency:0.00 ~ 600.00Hz DC brake current:0.0 ~ 100.0% DC brake time:0.0 ~ 100.00s



<b>Basic functions</b>	Input terminals	4 digital inputs, one of which can be used for high-speed pulse input 1 analog inputs, which is voltage/current optional
	Output terminals	1 digital output terminal, 2 Relay output terminal, 1 analog output ,Voltage and current outputs are optional, supporting 0~10V voltage or 0/4~20mA current outputs.
	Communication terminal	1 channel RS485 communication (standard), can support up to 38400bps communication rate
<b>Featured functions</b>	Parameter copy, parameter backup, common DC bus, parameters, flexible parameter displayed & hidden, various master & auxiliary setting and switchover, flying start, a variety of Accel/Decel curves optional, brake control, 16-step speed control programmable (2-step speed supports flexible frequency command), wobble frequency control, fixed length control, count function, three history faults, over excitation brake, over voltage stall protection, under voltage stall protection, restart on power loss, skip frequency, frequency binding, four kinds of Accel/Decel time, motor thermal protection, flexible fan control, process PID control, simple PLC, multi-functional key programmable, droop control, autotuning, field-weakening control, high-precision torque restraint, V/f separated control	
<b>Protection functions</b>	Refer to Chapter 6-Trouble Shooting	
<b>Environment</b>	Place of operation	Indoors, no direct sunlight, free from dust, corrosive gases, flammable gases, oil mist, water vapor, water drop or salt, etc.
	Altitude	0~2000m. De-rate 1% for every 100m when the altitude is above 1000 meters
	Ambient temperature	-10℃~50℃, The rated output current should be derated 1% for every 1℃ when the ambient is 40℃~50℃
	Relative humidity	5~95%, no condensation
	Vibration	Less than 5.9m/s <sup>2</sup> (0.6g)
	Storage temperature	-20℃~+60℃
<b>Others</b>	Efficiency at rated Amps	Rated power 7.5kW and below: ≥93% 11~22kW: ≥ 95%
	Installation	Standard: wall-mounted; Optional: 5.5kW and below DIN-Rail Mount, 7.5kW and above embedded installation
	IP grade	IP20
	Cooling method	Forced air cooling, Natural cooling

**2.4 Appearance, Mounting Dimensions**

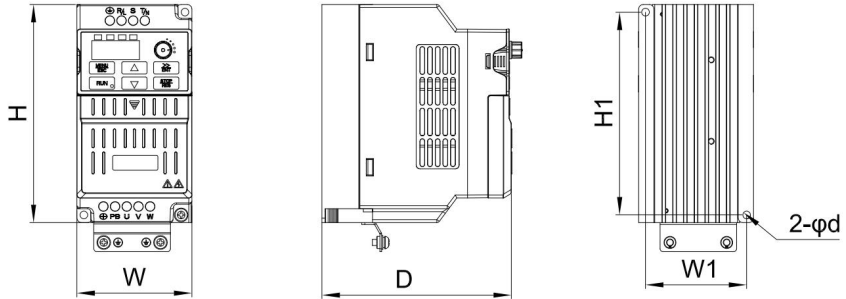

Fig. 2.4-1 Overall dimensions of FG210-2S、2T(0.4kW~1.5kW)、  
FG210-4T(0.4kW~2.2kW)

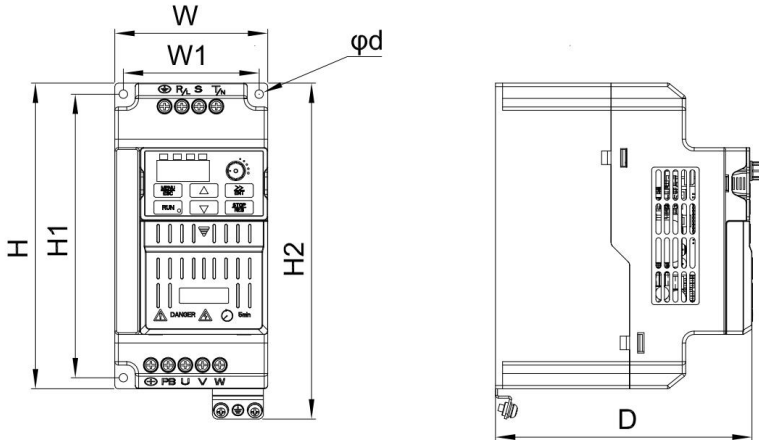

Fig. 2.4-2 Overall dimensions of FG210-2S、2T(2.2kW)、  
FG210-4T(4.0kW~5.5kW)

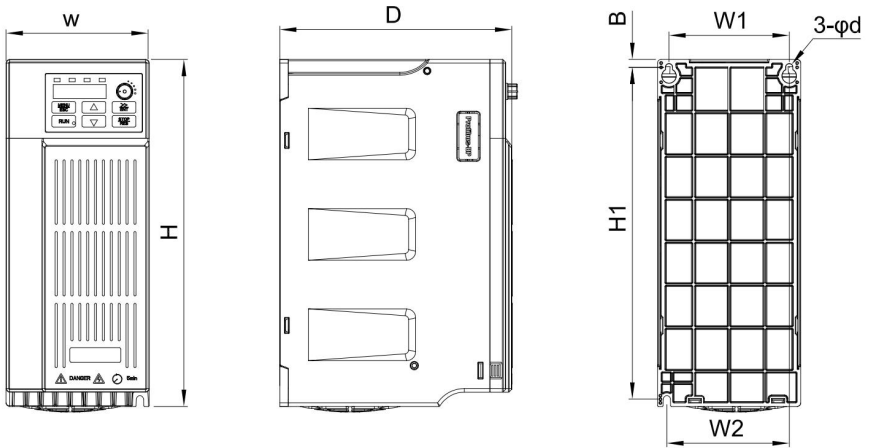

Fig. 2.4-3 Overall dimensions of FG210-4T(7.5kW~22kW)

Table 2.4-1 Appearance, mounting dimensions and weight

Model	External dimensions (mm)			Installation dimensions (mm)			Mounting aperture (mm) d	NW (Kg)
	H	D	W	W1	W2	H1		
Single-phase power supply:220V,50/60Hz Range:-15%~+15%								
FG210-2S-0.4GB	142	123	75	66	/	132	5	0.9
FG210-2S-0.75GB	142	138	75	66	/	132	5	1.0
FG210-2S-1.5GB								
FG210-2S-2.2GB	180	151	90	80	/	167	5	1.4
Three-phase power supply:220V,50/60Hz Range:-15%~+15%								
FG210-2T-0.4GB	142	123	75	66	/	132	5	0.9
FG210-2T-0.75GB	142	138	75	66	/	132	5	1.0
FG210-2T-1.5GB								
FG210-2T-2.2GB	180	151	90	80	/	167	5	1.4
Three-phase power supply:380V,50/60Hz Range:-15%~+15%								
FG210-4T-0.4GB/0.75PB	142	138	75	66	/	132	5	1.0
FG210-4T-0.75GB/1.5PB								
FG210-4T-1.5GB/2.2PB								
FG210-4T-2.2GB/3.0PB	180	151	90	80	/	167	5	1.4
FG210-4T-4.0GB/5.5PB								
FG210-4T-5.5GB/7.5PB								
FG210-4T-7.5GB/11PB	242	165	100	84	85	232	5	2.6
FG210-4T-11GB/15PB	320	181	116	98	98	307	5.5	3.5

## FG210 User Manual

---

Model	External dimensions (mm)			Installation dimensions (mm)			Mounting aperture (mm)	NW (Kg)
	H	D	W	W1	W2	H1	d	
FG210-4T-15GB/18.5PB	383	223.5	142	125	100	372	5.5	7
FG210-4T-18.5GB/22PB								
FG210-4T-22GB/30PB								

## 2.5 External Dimensions of Control Panel

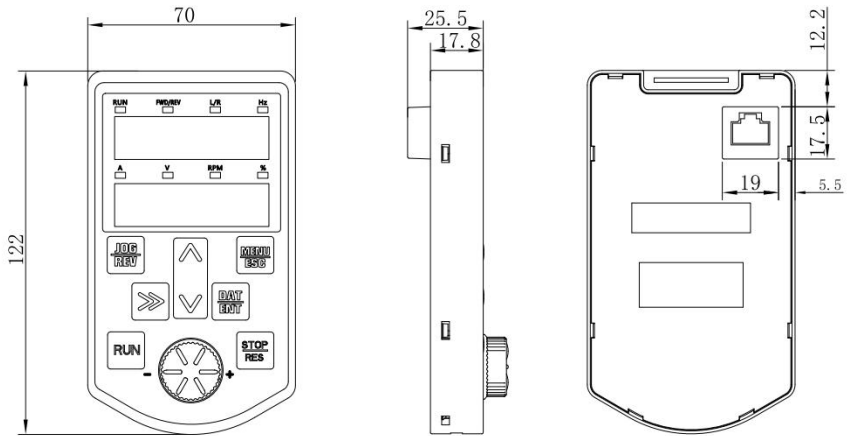

Fig. 2.5-1 External dimensions of LED Control Panel

### 2.6 External Dimensions of Control Panel Bracket

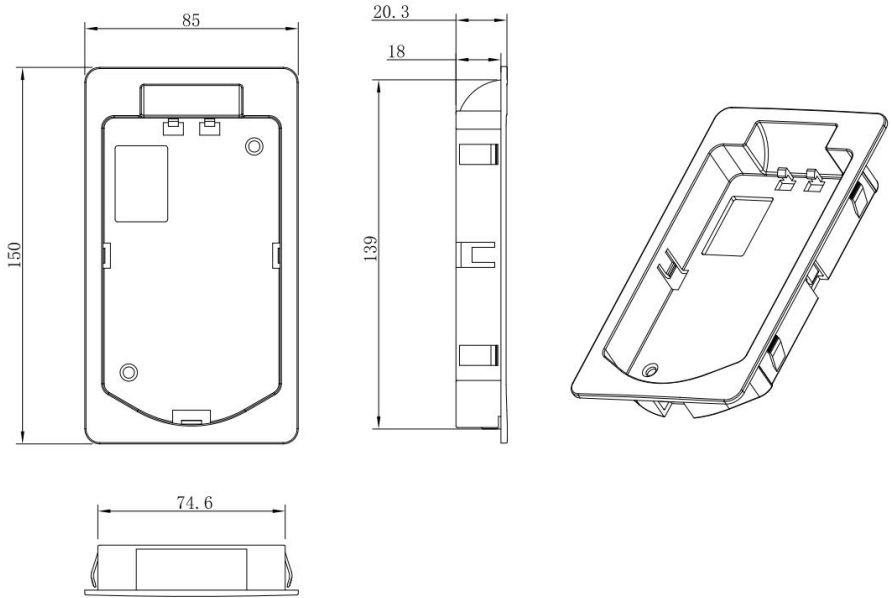

Fig. 2.6-1 External Dimensions of Control Panel Bracket

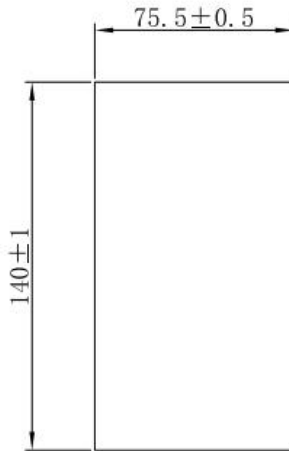

Fig. 2.6-2 Hole dimensions in the cabinet

## 2.7 Guide to Select Brake Components

Table 2.7-1 Selection of FG210 drive brake components

Model	Recommended power for brake resistance	Recommended brake resistance	Brake unit
Single-phase power supply:220V,50/60Hz		Range:-15%~+15%	
FG210-2S-0.4GB	80W	≥150Ω	Inbuilt
FG210-2S-0.75GB	80W	≥150Ω	
FG210-2S-1.5GB	100W	≥100Ω	
FG210-2S-2.2GB	100W	≥70Ω	
Three-phase power supply:220V,50/60Hz		Range:-15%~+15%	
FG210-2T-0.4GB	80W	≥150Ω	Inbuilt
FG210-2T-0.75GB	80W	≥150Ω	
FG210-2T-1.5GB	100W	≥100Ω	
FG210-2T-2.2GB	100W	≥70Ω	
Three-phase power supply:380V,50/60Hz		Range:-15%~+15%	
FG210-4T-0.4GB/0.75PB	150W	≥150Ω	Inbuilt
FG210-4T-0.75GB/1.5PB	150W	≥150Ω	
FG210-4T-1.5GB/2.2PB	150W	≥150Ω	
FG210-4T-2.2GB/3.0PB	300W	≥100Ω	
FG210-4T-4.0GB/5.5PB	300W	≥76Ω	
FG210-4T-5.5GB/7.5PB	400W	≥76Ω	
FG210-4T-7.5GB/11PB	500W	≥76Ω	
FG210-4T-11GB/15PB	800W	≥40Ω	
FG210-4T-15GB/18.5PB	1000W	≥27Ω	
FG210-4T-18.5GB/22PB	4.0kW	≥27Ω	
FG210-4T-22GB/30PB	4.5kW	≥27Ω	

**Description:**

- When brake unit is built in, the power and resistance value of brake resistor should meet the requirement as stated in the table.
- On the premise of fulfilling brake requirement, brake resistance value might be bigger than the minimum value as stated in the table. Failure to comply may result in damage to the drive.

# Chapter 3 Installation and Wiring

## 3.1 Installation Environment

- 1) Ambient temperature is in the range of  $-10^{\circ}\text{C} \sim 40^{\circ}\text{C}$ .
- 2) Drive should be installed on surface of flame retardant object, with adequate surrounding space for heat dissipation.
- 3) Installation should be performed where vibration is less than  $5.9\text{m/s}^2$  (0.6g).
- 4) Protect from moisture and direct sunlight.
- 5) Protect the cooling fan by avoiding oil, dust and metal particles.
- 6) Do not expose to an atmosphere with flammable gases, corrosive gases, explosive gases or other harmful gases.
- 7) Prevent drilling residues, wire ends and screws falling into drive.
- 8) Ventilation part of the drive should be installed outside from harsh environment (e.g. textile facilities with fiber particles and chemical facilities filled with corrosive gases).

## 3.2 Minimum Mounting Clearances

Installation is in an indoor, well-ventilated location and should generally be vertical. Installation interval and distance requirements, as shown below.

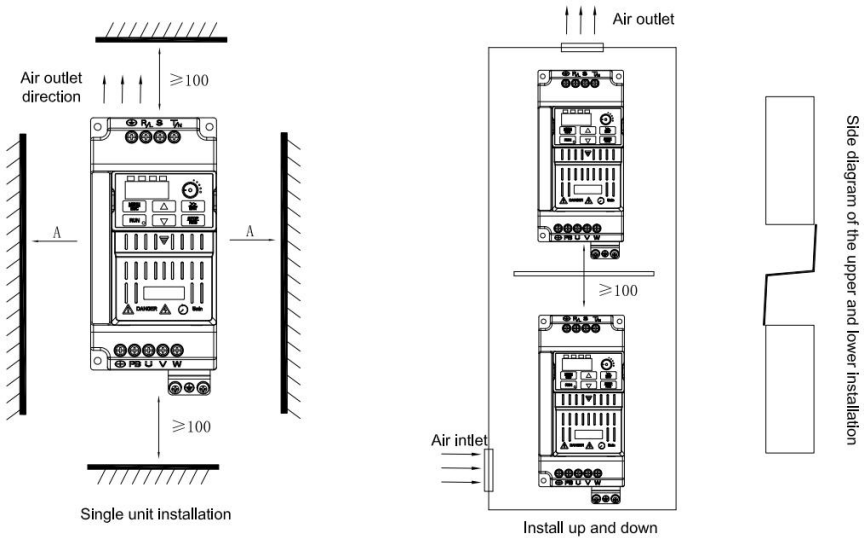

Fig. 3.2-1 Installation of AC drive



Upper and lower installation:When installing the drives up and down, please install the Air Guide Plate shown in the figure.

Power level	Mounting dimensions for upper and lower installation	A
0.4kW~22kW	≥100mm	≥8mm

### 3.3 Remove & Mount Control Panel and Cover

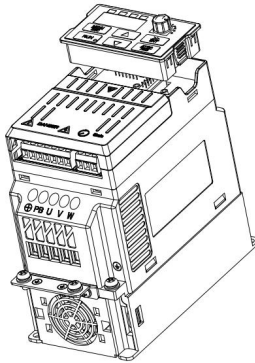

Fig. 3.3-1 Remove and Mount Control Panel

- **Remove control panel:**

Remove the control panel by lightly pressing the left and right sides of the control panel with your fingers and then pulling up.

- **Mount control panel:**

First, dock the bottom fixing clips of the control panel on the mounting claws underneath the mounting slots of the operating panel, press down with your fingers after pressing the shrapnel on both sides, and release your fingers after it is in place.

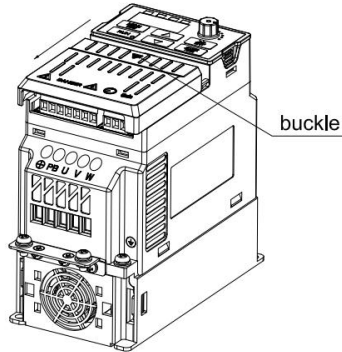

Fig. 3.3-2 Removal and installation diagram of the plastic cover plate below 5.5kW

- **Removal of plastic shell cover plate:**  
Press the clasp down with your finger and push it out in the direction of the arrow shown.
- **Installation of plastic shell cover plate:**  
Simply push the top end of the cover into the outer case first, then slide the cover upward.

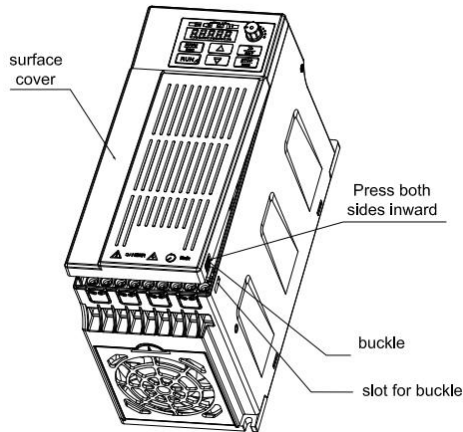

Fig. 3.3-3 Removal and Installation Schematic of Plastic Housing Cover for 7.5kW and Above

- **Removal of plastic shell cover plate:**  
Use a finger or a tool to hook the lower end of the cover plate to the inside.
- **Installation of plastic shell cover plate:**  
First push the upper hook of the cover into the outer box, and then press the lower hook of the cover into the outer box.

### 3.4 Wiring Diagram

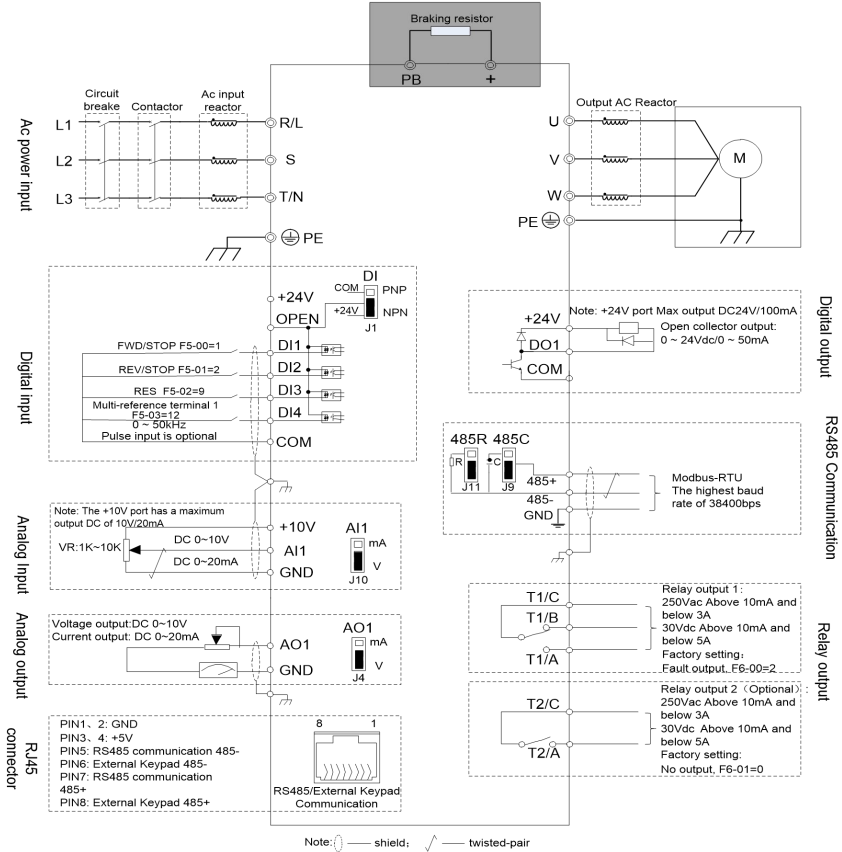

Fig. 3.4-1 Wiring diagram

**Notice:**

- ① Terminal Ⓞ Indicates the main loop terminal, ○ indicates the control loop terminal;
- ② The "B" at the back of the product model means the inbuilt brake unit of the standard model. The brake resistance can be selected according to the user's needs. See Table 2.7-1 Brake assembly selection guide;
- ③ Signal cables and power cables must be routed separately, and the control cables and power cables should be crossed at a 90-degree Angle as far as possible. The analog signal line reference diagram describes the selection of linear, power cable is the best choice of shielded three core cable;
- ④ Single-phase 220V model power terminals are L and N.

### 3.5 Control Terminal Specification

#### 3.5.1 Schematic diagram of control board layout

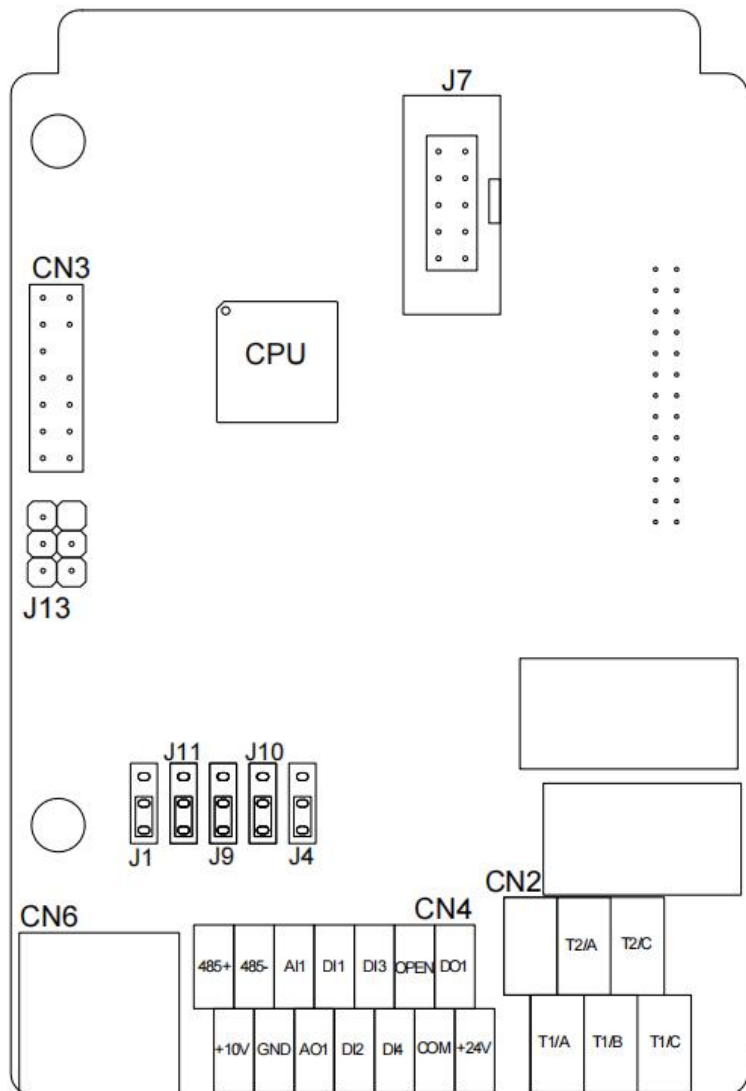

Fig. 3.5-1 0.4kW~5.5kW Schematic diagram of control board layout

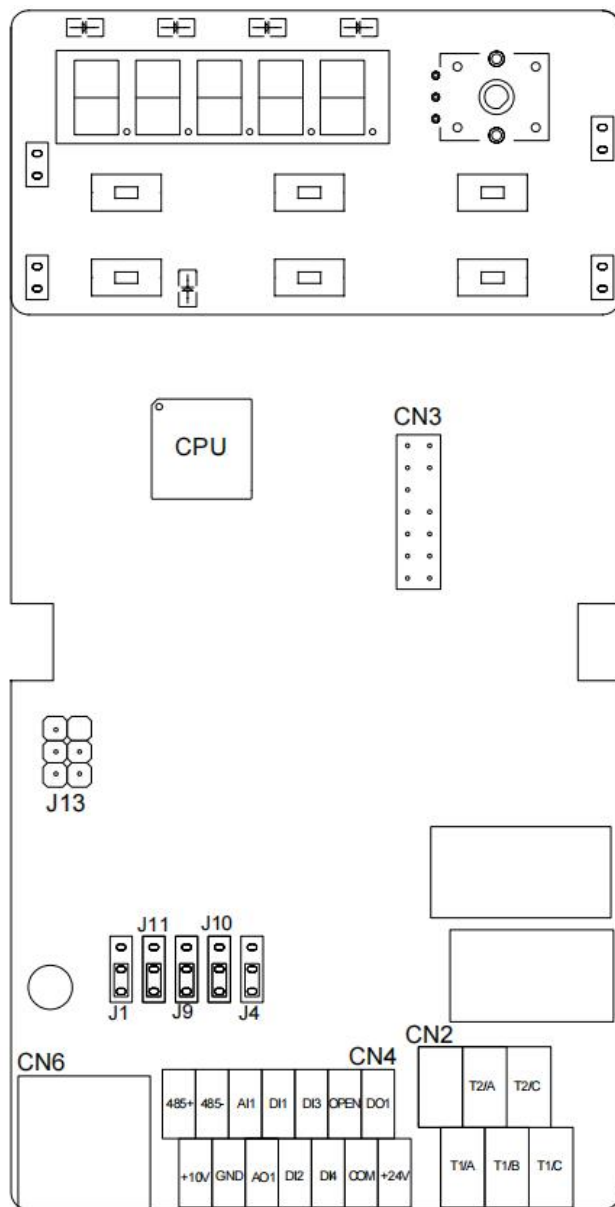

Fig. 3.5-2 7.5kW~22kW Schematic diagram of control board layout

**3.5.2 Function description of the control terminals**

Table 3.5-1 Functions of control terminals

Category	Terminal	Terminal Name	Function Description
Power source	10V-GND	+10V power supply	<ol style="list-style-type: none"> <li>External 10V power supply</li> <li>Generally used for external potentiometer power supply, potentiometer resistance range 1kΩ~10kΩ</li> <li>Maximum output current 20mA</li> </ol>
	24V-COM	+24Vpower supply	<ol style="list-style-type: none"> <li>Provide +24V power supply to external unit. Generally, it provides power supply to DI/DO terminals and external sensors.</li> <li>Maximum output current:100mA</li> <li>Do not use this power supply as an external power supply</li> </ol>
Analog input	AI1	Analog input terminal	Supports 0V to 10V voltage or 0/4mA to 20mA current input, which is selected by jumper AI1(J10). The default voltage input is 0V to 10V
Digital input	DI1	Digit input terminal 1	<ol style="list-style-type: none"> <li>Multifunctional digital input, through F5-00 to F5-03 to set the function</li> <li>Supports external NPN and PNP input. You can select the input mode by using jumper DI1(J1). By default, the input mode is NPN</li> <li>DI4 can be used as a pulse input terminal. This function is optional.</li> </ol>
	DI2	Digit input terminal 2	
	DI3	Digit input terminal 3	
	DI4	Digit input terminal 4	
Analog output	AO1	Analog output terminal	Support 0V~10V voltage or 0/4mA~20mA current output, selected by jumper AO1(J4), default is 0V~10V voltage output
Digital output	DO1	Digital output	<ol style="list-style-type: none"> <li>DO1 open-collector output</li> <li>Pull-up voltage range: 5V~24V (resistance range: 1kΩ~10kΩ)</li> <li>Output current range:0~50mA</li> </ol>
Relay Output 1	T1/A-T1/C	Relay T1 normally open terminal	Contact drive capacity: AC250V, 3A; DC30V, 5A
	T1/B-T1/C	Relay T1 normally closed terminal	
Relay Output 2	T2/A-T2/C	Relay T2 normally open terminal	
485 communication	485+ - 485-	RS-485 communication terminal	<ol style="list-style-type: none"> <li>Standard RS-485 communication terminals, use twisted-pair shielded cables</li> <li>Terminal resistance 120R is selected by jumper 485R. The default is no terminal resistance</li> <li>Communication filter capacitor is selected by jumper 485C. The default value is no filter capacitor</li> </ol>

### 3.5.3 Cable Connections to Main control board terminals

#### 3.5.3.1 Digital input terminal

Multi-function digital input terminals can support NPN or PNP mode access, DI1 ~ DI4 terminals and external connection is very flexible, through the J1 position on the control board DI jump cap to select NPN or PNP two modes (factory default is NPN mode). Multi-function digital input terminals of different modes of jump caps and wiring as shown in Figure 3.5-3~3.5-6:

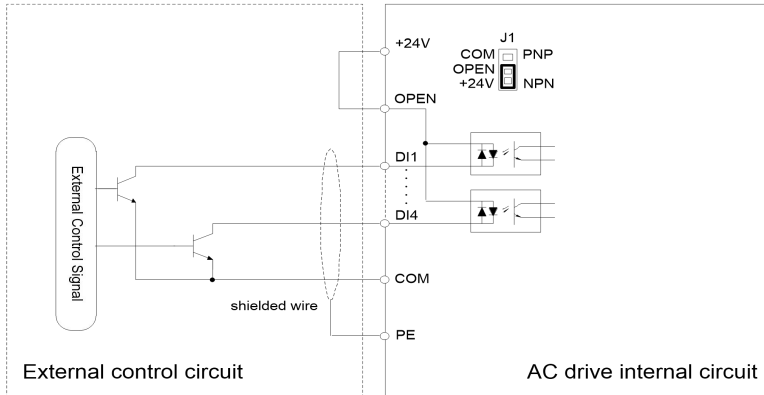

Fig. 3.5-3 NPN mode Uses the internal power supply

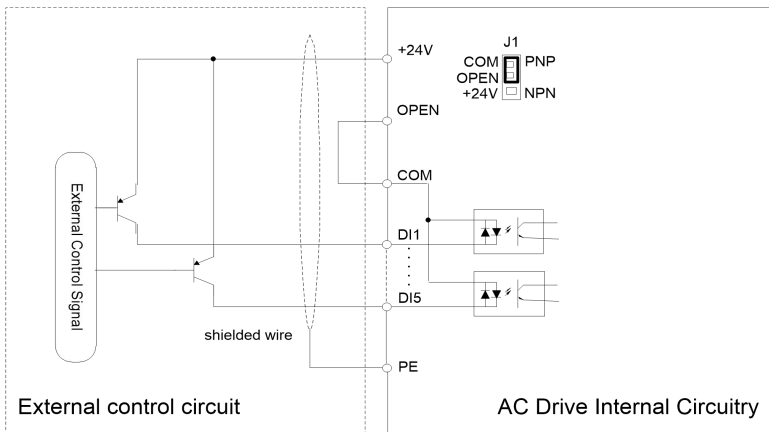

Fig. 3.5-4 PNP mode uses an internal power supply

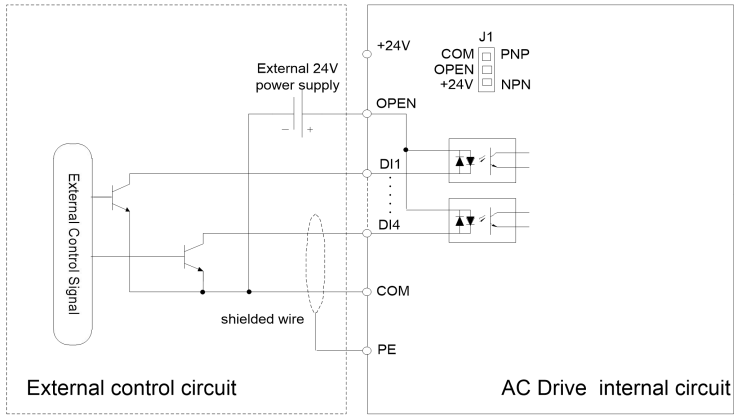

Fig. 3.5-5 NPN mode Uses external power supplies

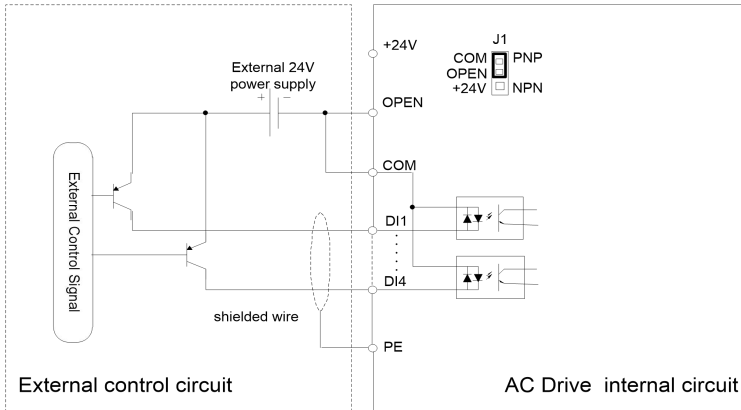

Fig. 3.5-6 PNP mode uses an external power supply

**Precautions:**

When using an external power supply accessed in NPN mode, the jumper cap for the J1 position DI block must be removed.

**3.5.3.3 Digital Output terminal**

When the digital output terminal DO1 needs to drive the relay, the absorption diode should be installed on both sides of the relay coil, otherwise it may cause damage to DC +24V power supply, and the driving capacity of DO1 is not greater than 50mA.



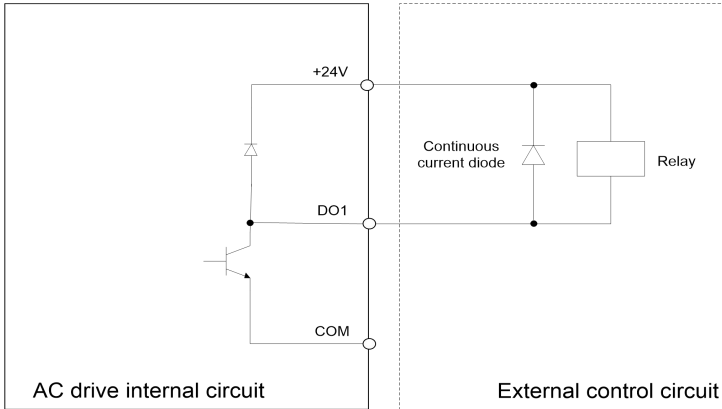

Fig. 3.5-7 Digital output terminal using an open-collector output

### 3.5.3.4 Analog output terminal

The analog output terminal AO1 external analog quantity can represent a variety of physical quantities. You can select the output current (0/4 ~ 20mA) or (0 ~ 10V) through the J4 position on the control board DI jump cap. Figure 3.5-8 and 3.5-9 show dip switches and terminal wiring methods.

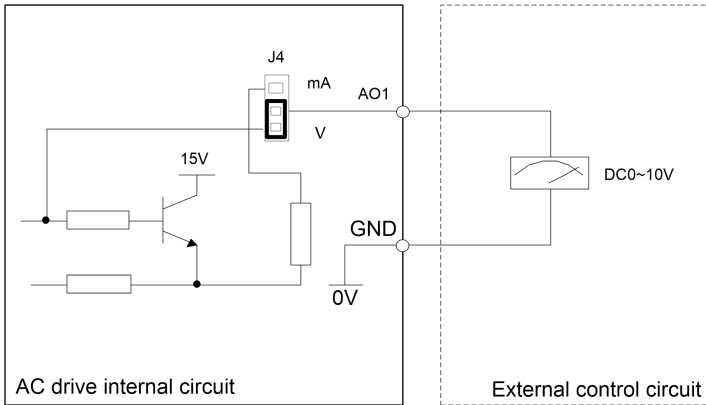

Fig. 3.5-8 Analog output terminal output voltage signal wiring diagram

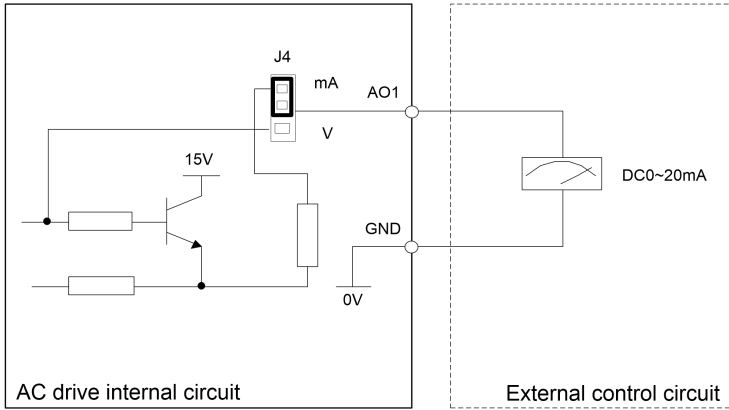
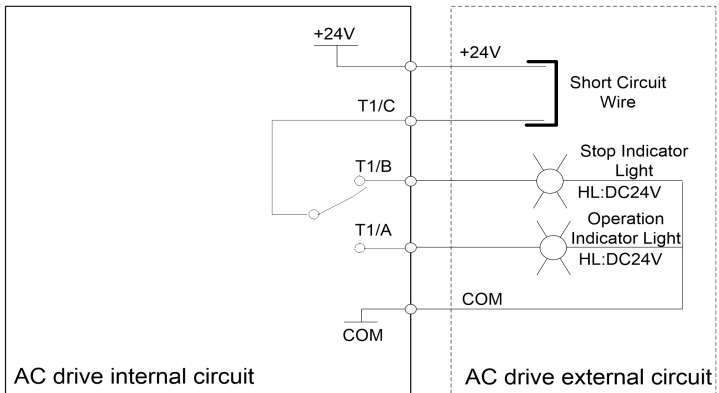

Fig. 3.5-9 Analog output terminal output current signal wiring diagram

3.5.3.5 Relay Output terminal

The wiring of relay output terminals is shown in Fig. 3.5-10, where TC is the common end of relay contacts, TB is the normally closed terminal, TA is the normally open terminal, and the driving load of relay does not exceed AC 250V 3A and DC 30V 5A.



Use internal DC24V power supply

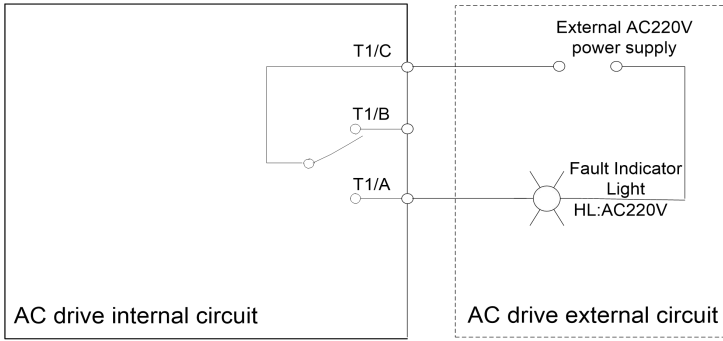

Use external AC220V power supply

Fig. 3.5-10 Wiring diagram of relay output terminal

When the relay output is connected to the inductive load (such as relay, contactor or motor), voltage peak will be caused when the current is cut off. Therefore, it is better to add varistor to the relay contact for protection, and install absorbent circuit, such as varistor, RC absorbent circuit or diode, on the inductive load to ensure the minimum interference during shutdown. For details, see Fig. 3.5-11:

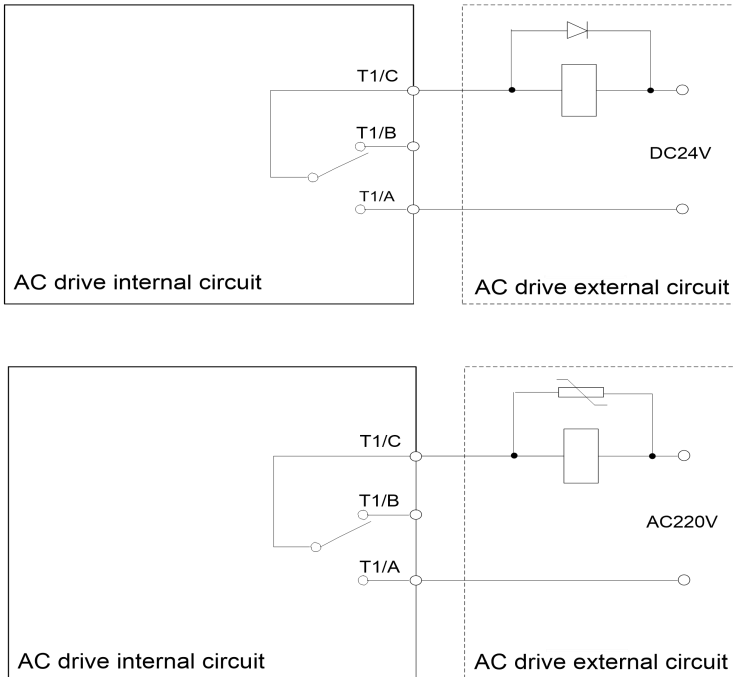

Fig. 3.5-11 Relay output terminal anti-interference processing

**3.5.3.6 RS485 Communication Terminal**

Communication terminals 485+ and 485- are the RS485 communication interfaces of the Drive. 485+ is connected to the positive end of the communication of the host computer, and 485- is connected to the negative end of the host computer, realizing the networking control between the host computer (PC or PLC controller) and the Drive. The connection between RS485 and the Drive is shown in Fig. 3.5-12 below:

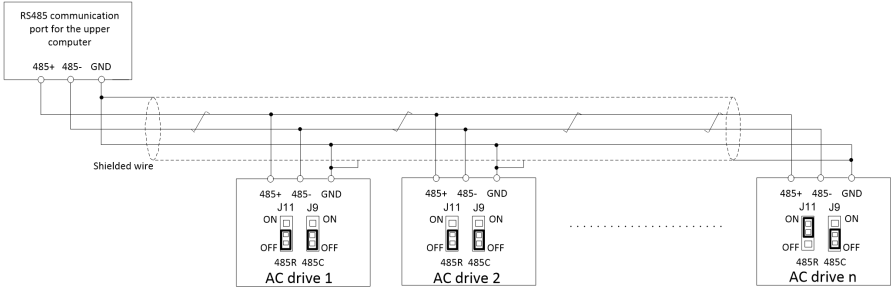

Fig. 3.5-12 RS485 communication terminal wiring diagram of one or multiple drive

RS485 communication as far as possible using twisted shielded wire, and all communication GND short, multi-machine communication, in the most terminal inverter J11 jumper cap position adjusted to the upper two feet (connected to the terminal resistance)

# Chapter 4 Operation and Run Instructions

## 4.1 Operation of Control Panel

As a human-machine interface, control panel is the main part for the drive to receive command and display parameters.

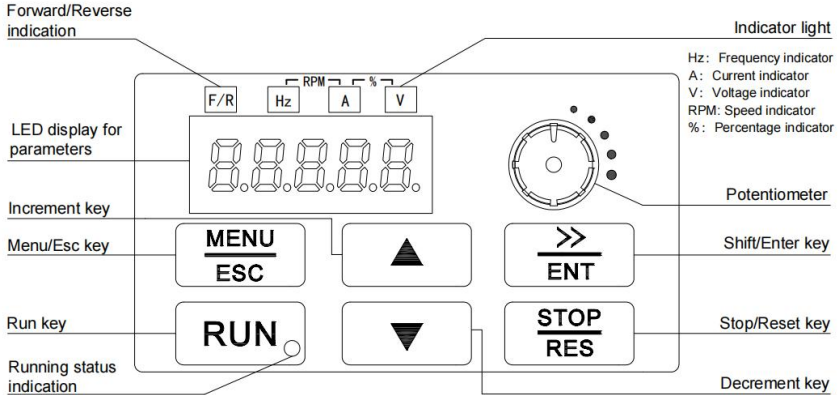

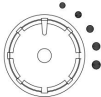

Fig.4.1-1 Control panel

### 4.1.1 Key Functions on Control Panel

Symbol	Key name	Meaning
	MENU/ESC	1) Enter or exit Level 1 menu. 2) Return to the previous menu.
	Increment	1) When navigating a menu, it moves the selection up through the screens available. 2) When editing a parameter value, it increases the displayed value. 3) When the AC drive is in RUNNING mode, it increases the speed.
	Decrement	1) When navigating a menu, it moves the selection down through the screens available. 2) When editing a parameter value, it decreases the displayed value. 3) When the AC drive is in RUNNING mode, it decreases the speed.
	Shift/Enter	In the stop display interface and the operation display interface, you can select the display parameters. When modifying the parameters, you can select the modification bit of the parameters. Long time ( $\geq 1s$ ), you can enter the menu interface step by step, set parameters to confirm.

## FG210 User Manual

Symbol	Key name	Meaning
	RUN	Start the AC drive when using the operating panel control mode. It is inactive when using the terminal or communication control mode.
	STOP/RES	1) Stop the AC drive when the drive is in the RUNNING status. 2) Perform a reset operation when the drive is in the FAULT status.
	Potentiometer	A clockwise rotation increases the operation value and a counterclockwise rotation decreases the operation value.

### 4.1.2 Status Indicators

Status Indicators	Display light name	Indication
RUN	Running status indication	ON indicates the RUNNING status. OFF indicates the STOP status. Blinking indicates the fault alarm state.
F/R	Forward/Reverse indication	ON indicates forward motor rotation. OFF indicates reverse motor rotation. Blinking indicates the forward/reverse switchover status.
Hz	Frequency indication	Hz for frequency
A	Current indication	A for current
V	Voltage indication	V for voltage
Hz+A	Rotation speed indication	The current displayed parameter is speed, unit: RPM
A+V	Percentage indication	The displayed parameter is percentage (unit: %)

## 4.2 Quick setup

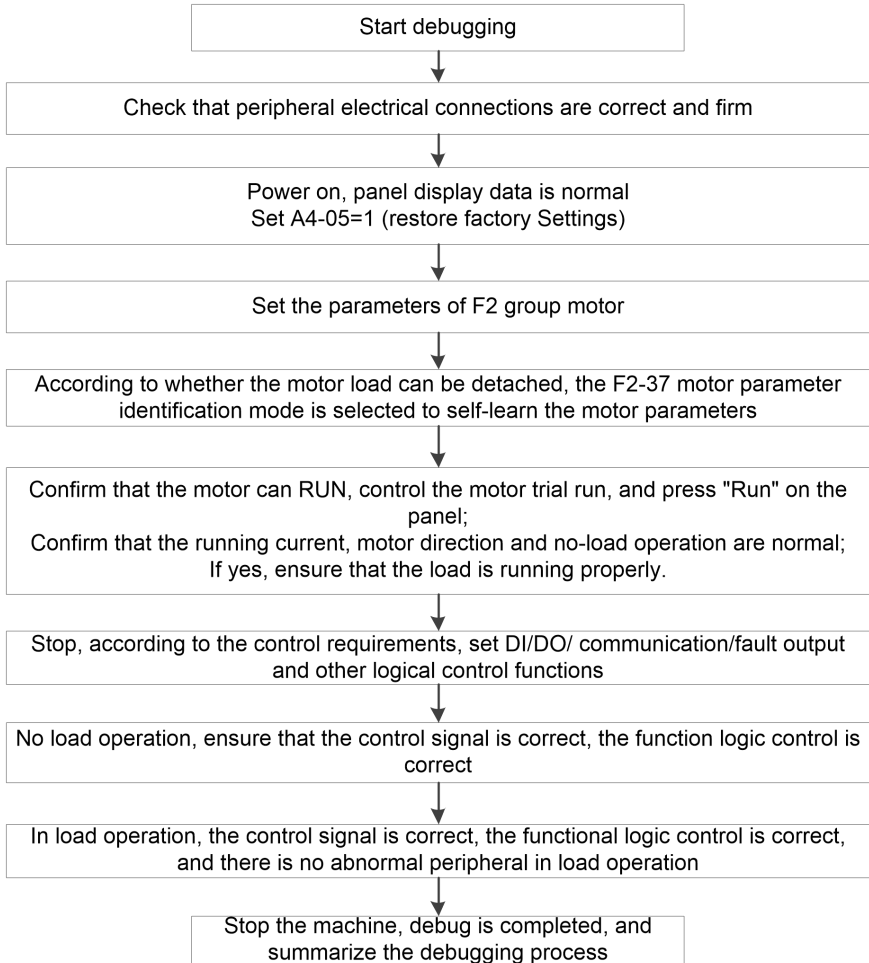





Function Code	Parameter Name	Setting Range	Default	Property
F0-04	Auxiliary frequency source Y selection	0:UP/ DOWN setting (non-recorded after stop) 1:UP/ DOWN setting (retentive after stop) 2:A11                                   3:Reserved 4:Multi-speed                   5:Simple PLC 6:PID 7:Communication setting 8:Pulse setting 9:UP/ DOWN setting(Downtime memory Power down does not remember) 10:Keyboard potentiometer	0	★
F0-05	Auxiliary frequency source Y range selection	0:Relative to maximum frequency 1:Relative to main frequency X 2:The range is the same as 0 but the main and auxiliary have no negative frequency output	0	☆
F0-06	Coefficient of auxiliary frequency Y	0~10.000	1.000	☆
F0-07	Digital frequency	0.00 to maximum frequency A0-00	50.00Hz	☆
F0-08	Forward Frequency source upper limit	0:Set by F0-09   1:A11   2:Reserved 3:Communication setting   4:Pulse setting	0	★
F0-09	Forward Frequency upper limit	Frequency lower limit F0-11 to maximum frequency A0-00	50.00Hz	☆
F0-10	Reverse Frequency upper limit	Frequency lower limit F0-11 to maximum frequency A0-00	50.00Hz	☆
F0-11	Frequency lower limit	0.00 Hz to frequency upper limits F0-09	0.00Hz	☆
F0-12	Rotation direction	Unit's digit :Motor direction selection 0:Same direction           1:Reverse direction Ten's digit:Reverse control 0:Reverse allowed       1:Reverse forbidden	00	★
F0-13	Command source binding select	Unit's digit:Binding operation keypad command to frequency source 0:No Binding               1:Digital setting 2:A11                           3:Reserved 4:Multi-speed               5:Simple PLC 6:PID 7:Communication setting 8:Pulse setting (DI4) Ten's digit:Binding operation terminal command to frequency source Hundred's digit:Binding operation communication command to frequency source Thousand's digit:Reserved	000	☆
F0-14	Acceleration/Deceleration time unit	0:1s   1:0.1s   2:0.01s	1	★

## FG210 User Manual

Function Code	Parameter Name	Setting Range	Default	Property
F0-15	Acceleration/Deceleration time base frequency	0:Maximum frequency (A0-00) 1:Set frequency(F0-07) 2:Rated motor frequency (F2-04)	0	★
F0-16	Acceleration time 1	0s~30000s(F0-14=0) 0.0s~3000.0s(F0-14=1) 0.00s~300.00s(F0-14=2)	Model dependent	☆
F0-17	Deceleration time 1	0s~30000s(F0-14=0) 0.0s~3000.0s(F0-14=1) 0.00s~300.00s(F0-14=2)	Model dependent	☆
F0-18	Acceleration time 2	0.0s~3000.0s	10.0s	☆
F0-19	Deceleration time 2	0.0s~3000.0s	10.0s	☆
F0-20	Acceleration time 3	0.0s~3000.0s	10.0s	☆
F0-21	Deceleration time 3	0.0s~3000.0s	10.0s	☆
F0-22	Acceleration time 4	0.0s~3000.0s	10.0s	☆
F0-23	Deceleration time 4	0.0s~3000.0s	10.0s	☆
F0-24	Frequency switchover point between acceleration time 1 and acceleration time 2	0.00 Hz to maximum frequency	0.00Hz	☆
F0-25	Frequency switchover point between deceleration time 1 and deceleration time 2	0.00 Hz to maximum frequency	0.00Hz	☆
F0-26	Acceleration/Deceleration mode	0:Linear Acceleration/Deceleration mode 1:S-curve Acceleration/Deceleration mode A 2:S-curve Acceleration/Deceleration mode B(F0-27~F0-30 units are 0.01s)	0	★
F0-27	Acceleration time proportion of S-curve start segment	0.0%~100.0%	20.0%	★
F0-28	Acceleration time proportion of S-curve end segment	0.0%~100.0%	20.0%	★
F0-29	Deceleration time proportion of S-curve start segment	0.0%~100.0%	20.0%	★
F0-30	Deceleration time proportion of S-curve end segment	0.0%~100.0%	20.0%	★



## FG210 User Manual

Function Code	Parameter Name	Setting Range	Default	Property
F1-10	Rotational speed tracking mode	0:From frequency at stop 1:From aim frequency 2:From maximum frequency	0	★
F1-11	Max current of rotational speed tracking	30%~150%	100%	★
F1-12	Rotational speed tracking speed	1~100	20	☆
F1-13	Nonstop at instantaneous stop (when power fail) mode selection	0:Ineffective 1:Automatic start at power fluctuation 2:Decelerate to stop	0	★
F1-14	Deceleration time of nonstop at instantaneous stop	0.0s ~100.0s	10.0s	★
F1-15	Effective voltage of nonstop at instantaneous stop	60%~85%	80%	★
F1-16	Recovery voltage of nonstop at instantaneous stop	85%~100%	90%	★
F1-17	Detection time of instantaneous stop nonstop recovery voltage	0.0s~300.0s	0.3s	★
F1-18	Auto-regulation gain of nonstop at instantaneous stop	0~100	40	☆
F1-19	Auto-regulation integral time of nonstop at instantaneous stop	1~100	20	☆
F1-20	Speed tracks closed-loop current KP	0~1000	500	☆
F1-21	Speed tracks closed-loop current KI	0~1000	800	☆
F1-22	speed tracks the limit value under the closed-loop current	10~100	30	☆
F1-23	Speed tracks voltage rise time	5s~30s	11s	☆
F1-24	Rotational speed tracks demagnetization time	0.01s~3.00s	0.50s	★

Function Code	Parameter Name	Setting Range	Default	Property
<b>Group F2: Motor 1 Parameters</b>				
F2-00	Motor 1 Control mode	1:Sensorless vector control (SVC) 2:Voltage/Frequency control(V/F)	2	★
F2-01	Rated motor 1 power	0.1kW~1000.0kW	Model dependent	★
F2-02	Rated motor 1 voltage	1V~1500V	Model dependent	★
F2-03	Rated motor 1 current	0.01A~600.00A (motor rated power ≤30 kW). 0.1A~6000.0A (motor rated power >30kW).	Model dependent	★
F2-04	Rated motor frequency	0.01Hz~A0-00max-frequency	Model dependent	★
F2-05	Rated motor 1 rotational speed	1rpm~60000rpm	Model dependent	★
F2-06	Number of pole pairs of motor 1	2~64	Model dependent	○
F2-07	Motor 1 stator resistance	0.001Ω~65.535Ω	Model dependent	★
F2-08	Motor 1 rotor resistance	0.001Ω~65.535Ω	Model dependent	★
F2-09	Motor 1 mutual inductive	0.1Mh~6553.5Mh	Model dependent	★
F2-10	Motor 1 leakage inductive	0.01Mh~655.35Mh	Model dependent	★
F2-11	Motor 1 no-load current	0.01A~F2-03 (motor rated power ≤30 kW). 0.1A~ F2-03 (motor rated power >30kW).	Model dependent	★
F2-12~ F2-34	Reserved			
F2-35	Acceleration time of complete auto-tuning	1.0s~6000.0s	10.0s	☆
F2-36	Deceleration time of complete auto-tuning	1.0s~6000.0s	10.0s	☆
F2-37	Auto-tuning selection	0:No auto-tuning 1:Static auto-tuning 2:Complete auto-tuning	0	★
<b>Group F3:Vector Control Parameters</b>				
F3-00	Switchover frequency 1	0.00Hz~F3-03	5.00Hz	☆
F3-01	Speed loop proportional gain at low frequency	0.1~10.0	4.0	☆

## FG210 User Manual

Function Code	Parameter Name	Setting Range	Default	Property
F3-02	Speed loop integral time at low frequency	0.01s~10.00s	0.50s	☆
F3-03	Switchover frequency 2	F3-00~A0-00	10.00Hz	☆
F3-04	Speed loop proportional gain at high frequency	0.1~10.0	2.0	☆
F3-05	Speed loop integral time at high frequency	0.01s~10.00s	1.00s	☆
F3-06	Speed loop integral property	0:Integral take effect 1:Integral separation	0	★
F3-07	Excitation adjustment proportional gain Kp	0~30000	2200	☆
F3-08	Excitation adjustment integral gain Ki	0~30000	1500	☆
F3-09	Torque adjustment proportional gain Kp	0~30000	2200	☆
F3-10	Torque adjustment integral gain Ki	0~30000	1500	☆
F3-11	Speed loop feedback filter time	0.000s~1.000s	0.015s	☆
F3-12	Speed loop output filter time	0.000s~1.000s	0.000s	☆
F3-13	Flux braking gain	0~200	0	☆
F3-14	Slip compensation gain	0%~200%	100%	☆
F3-15	Field weakening torque correction ratio	50%~200%	100%	☆
F3-16	Source of power-driven torque	0:F3-17      1:A11      2:Reserved 3:Communication setting 4:Pulse setting (DI4) (Analog range corresponds to F3-17)	0	☆
F3-17	Power-driven torque upper limit	0.0%~200.0%	150.0%	☆
F3-18	Upper limit source of braking torque	0:F3-19      1:A11      2:Reserved 3:Communication setting 4:Pulse setting (DI4) (Analog range corresponds to F3-19)	0	☆
F3-19	Braking torque upper limit	0.0%~200.0%	150.0%	☆
<b>Group F4:V/F Control Parameters</b>				

Function Code	Parameter Name	Setting Range	Default	Property
F4-00	V/F curve setting	0:Linear V/F 1:Multi-point V/F 2:Square V/F 3:1.7-power V/F 4:1.5-power V/F 5:1.3-power V/F 6:Voltage and frequency complete separation 7:Voltage and frequency half separation	0	★
F4-01	Torque boost	0.0%~30.0%	0.0%	☆
F4-02	Cut-off frequency of torque boost	0.00Hz~ max frequency (A0-00)	25.00Hz	★
F4-03	Droop ration	0.0%~100.0%	0.0%	☆
F4-04	V/F Slip compensation time	0.02s~1.00s	0.30s	☆
F4-05	Slip compensation ratio	0.0%~200.0%	50.0%	☆
F4-06	Magnetic flux braking	0:Disable 1:Enable	1	★
F4-07	Magnetic flux brake Gain	0~512	256	☆
F4-08	Oscillation suppression gain mode	0~2	0	★
F4-09	Oscillation suppression gain	0~100	Model dependent	☆
F4-10	V/F overcurrent stall gain	0~100	20	☆
F4-11	V/F overcurrent stall protective current	50%~200%	150%	★
F4-12	V/F weak magnetic current stall protection coefficient	50%~200%	100%	★
F4-13	Output voltage source for voltage and frequency separation	0:Digital setting (F4-14) 1:A11 2:Reserved 3:Multi-reference 4:Simple PLC 5:PID 6:Communication setting. 7:Pulse setting (DI4). 100.0% corresponds to the rated.	0	☆
F4-14	Voltage digital setting for V/F separation	0V~rated motor voltage	0V	☆
F4-15	Voltage rise time of V/F separation	0.0s~3000.0s	1.0s	☆
F4-16	Voltage decline time of V/F separation	0.0s~3000.0s	1.0s	☆
F4-17	Stop mode selection	0:Frequency and voltage declining	0	☆

## FG210 User Manual

Function Code	Parameter Name	Setting Range	Default	Property
	upon V/F separation	independently 1:Frequency declining after voltage declines to 0		
F4-18	Multi-point V/F frequency 1 (F1)	0.00Hz~F4-20	1.30Hz	★
F4-19	Multi-point V/F voltage 1 (V1)	0.0%~100.0%	5.2%	★
F4-20	Multi-point V/F frequency 2 (F2)	F4-18~F4-22	2.50Hz	★
F4-21	Multi-point V/F voltage 2 (V2)	0.0%~100.0%	8.8%	★
F4-22	Multi-point V/F frequency 3 (F3)	F4-20~50.00 Hz	15.00Hz	★
F4-23	Multi-point V/F voltage 3 (V3)	0.0%~100.0%	35.0%	★
<b>Group F5: Input terminals</b>				
F5-00	DI1 function selection	See 5.2 DI function selection table	1	★
F5-01	DI2 function selection		2	★
F5-02	DI3 function selection		9	★
F5-03	DI4 function selection		12	★
F5-04~ F5-09	Reserved			
F5-10	DI filter time	0.000s~1.000s	0.010s	☆
F5-11	Terminal command mode	0:two-wire control mode 1 1:Two-wire control mode 2 2:Three-wire control mode 1 3:Three-wire control mode 2	0	★
F5-12	Terminal UP/DOWN rate	0.01Hz/s~100.00Hz/s	1.00Hz/s	☆
F5-13	Terminal effective mode 1	0:High level Unit's:DI1 Hundred's:DI3 Myriabit:Reserved 1:Low level Ten's:DI2 Kilobit:DI4	00000	★
F5-14	Reserved			
F5-15	AI1 minimum input	0.00V~10.00V	0.00V	☆
F5-16	Corresponding setting of AI1 minimum input	-100.0%~100.0%	0.0%	☆
F5-17	AI1 maximum input	0.00V~10.00V	10.00V	☆



Function Code	Parameter Name	Setting Range	Default	Property
F5-18	Corresponding setting of AI1 maximum	-100.0%~100.0%	100.0%	☆
F5-19~ F5-26	Reserved			
F5-27	AI1 filter time	0.00s~10.00s	0.10s	☆
F5-28~ F5-37	Reserved			
F5-38	Pulse minimum input	0.00kHz~50.00kHz	0.00kHz	☆
F5-39	Corresponding setting of pulse minimum input	-100.0%~100.0%	0.0%	☆
F5-40	Pulse maximum input	0.00kHz~50.00kHz	50.00kHz	☆
F5-41	Corresponding setting of pulse maximum input	-100.0%~100.0%	100.0%	☆
F5-42	Pulse filter time	0.00s~10.00s	0.10s	☆
F5-43	DI1 On delay time	0.0s~3600.0s	0.0s	☆
F5-44	DI1 Off delay time	0.0s~3600.0s	0.0s	☆
F5-45	DI2 On delay time	0.0s~3600.0s	0.0s	☆
F5-46	DI2 Off delay time	0.0s~3600.0s	0.0s	☆
F5-47	DI3 On delay time	0.0s~3600.0s	0.0s	☆
F5-48	DI3 Off delay time	0.0s~3600.0s	0.0s	☆
F5-49	AI1 function selection as DI terminal	0~53, as DI terminal function.	0	★
F5-50~ F5-51	Reserved			
F5-52	AI effective mode selection as DI terminal	0:High level effective 1:Low level effective	0x0	★
F5-53	AI curve selection	0:2 points curve F5-15~F5-18 1:Multi-point curve 1:A6-00~A6-07 2:Multi-point curve 2:A6-08~A6-15	0x0	☆
F5-54	AI Signal input type selection	0:Voltage style Unit's digit: AI1 1:Current style	0	☆
<b>Group F6: Output terminals</b>				

## FG210 User Manual

Function Code	Parameter Name	Setting Range	Default	Property
F6-00	Relay 1 function(TA/TB/TC)	See 5.3 DO function selection table	2	☆
F6-01	Relay 2 function(TA/TC)		0	☆
F6-02	DO1 function		1	☆
F6-03~ F6-08	Reserved			
F6-09	AO1 output function selection	0:Running frequency 1:Set frequency 2:Output current (100% Corresponds to 2 times rated current of the motor) 3:Output power (100% Corresponds to 2 times Motor power rating) 4:Output voltage (100% corresponds to the rated voltage of 1.2 times the driver) 5:Analog AI1 input 6:Reserved 7:Communication setting 8:Output torque 9:Length 10:Count value 11:Motor rotational speed 12:Output bus voltage(0 to 3 times of driver rated) 13:Pulse input 14:Output current 15:Output voltage(100.0% corresponds to 1000.0V) 16:Output torque (Actual value: -2 to +2 times of the rated value)	0	☆
F6-10~ F6-12	Reserved			
F6-13	AO1 minimum output	-100.0%~F6-15	0.0%	☆
F6-14	Minimum corresponds to AO1 output	0.00V~10.00V	0.00V	☆
F6-15	AO1 maximum output	F6-13~100.0%	100.0%	☆
F6-16	Maximum corresponds to AO1 output	0.00V~10.00V	10.00V	☆
F6-17~ F6-20	Reserved			
F6-21	RELAY1 output delay	0.0s~3600.0s	0.0s	☆
F6-22	RELAY2 pull delay	0.0s~3600.0s	0.0s	☆
F6-23	DO1 output delay	0.0s~3600.0s	0.0s	☆

Function Code	Parameter Name	Setting Range	Default	Property
F6-24~ F6-25	Reserved			
F6-26	RELAY1 disconnect delay	0.0s~3600.0s	0.0s	☆
F6-27	RELAY2 disconnect delay	0.0s~3600.0s	0.0s	☆
F6-28	DO1 disconnect delay	0.0s~3600.0s	0.0s	☆
F6-29~ F6-30	Reserved			
F6-31	AO output type	0:Voltage type                      1:Current type	00	☆
F6-32	DO valid logic selection	1:High level                              0:Low level Unit's digit:RELAY1 Ten's digit:RELAY2 Hundred's digit:DO1	0000	☆
F6-33	AI1 input voltage lower limit DO=40	0.00V~F6-34	2.00V	☆
F6-34	AI1 input voltage upper limit DO=40	F6-33~11.00V	8.00V	☆
<b>Group F7: Keypad Display</b>				
F7-00	STOP/RES function	0:STOP/RESET key enabled only in operation keypad control 1:STOP/RESET key enabled in any operation mode	0	☆
F7-01	JOG/REV key function selection	0:Forward JOG 1:Switchover between forward rotation and reverse rotation 2:Reverse JOG 3:Switchover between operation keypad control and remote command control	0	★
F7-02	LED display running parameters 1	0000 to 0xFFFF Bit00:Running frequency                      0001 Bit01:Set frequency                              0002 Bit02:Bus voltage (V)                              0004 Bit03:Output voltage                              0008 Bit04:Output current                              0010 Bit05:Output power (kW)                              0020 Bit06:DI input status                              0040 Bit07:DO output status                              0080 Bit08:AI1 voltage (V)                              0100 Bit09:Reserved                                      0200 Bit10:PID setting                                      0400 Bit11:PID feedback                                      0800 Bit12:Count value                                      1000 Bit13:Length value                                      2000 Bit14:load speed display                              4000 Bit15:PLC stage                                      8000	H.441F	☆

## FG210 User Manual

Function Code	Parameter Name	Setting Range	Default	Property
F7-03	LED display running parameters 2	0x000~0x1FF Bit00:target torque 0001 Bit01:output torque 0002 Bit02:pulse input frequency (KHz) 0004 Bit03:D14 input liner speed(m/min) 0008 Bit04:motor rotation speed 0010 Bit05:AC line current 0020 Bit06:Accumulative running time(h) 0040 Bit07:The current running time(min) 0080 Bit08~Bit15:reserved	H.010	☆
F7-04	LED display stop parameters	0x0001 to 0x1FFF Bit00:Set frequency 0001 Bit01:Bus voltage (V) 0002 Bit02:DI input status 0004 Bit03:DO output status 0008 Bit04:Al1 voltage (V) 0010 Bit05:Reserved 0020 Bit06:PID setting 0040 Bit07:PID feedback 0080 Bit08:Count value 0100 Bit09:Length value 0200 Bit10:Load speed display 0400 Bit11:PLC stage 0800 Bit12:Pulse input frequency 1000 Bit13~Bit15:Reserved	H.0043	☆
F7-05	Keypad UP/DOWN increment	0:Default mode 1:0.1Hz 2:0.5Hz 3:1Hz 4:2Hz 5:4Hz 6:5Hz 7:8Hz 8:10Hz	0	☆
F7-06	The second row of external LED runs to displays the parameters	0~15 corresponds to F7-02 bit0~bit15 16~31 corresponds to F7-03 bit0~bit15	4	☆
F7-07	The second row of external LED shutdown displays the parameters	0~14 corresponds to F7-04 bit0~bit14	1	☆
F7-08~F7-10	Reserved			
F7-11	Vector running frequency display selection	0:Real-time frequency 1:setting frequency	0	☆
F7-12	UP/Down regulation display selection	0:Display the setting value 1:Display the current variable value	0	☆
F7-13	keyboard version number is displayed	Version number of the functional software	###	●

Function Code	Parameter Name	Setting Range	Default	Property
<b>Group F8: Auxiliary Functions</b>				
F8-00	Improve function parameter display selecting	0:Hide improvement function parameter:A1~AA 1:Display improvement function parameter:A1~AA	1	☆
F8-01	User password	0~65535	0	☆
F8-02	Reserved			
F8-03	0Hz running way	0:No current output 1:Normal operation 2:Output with DC braking current F1-08	0	☆
F8-04	Setting power-on reached	0h~65530h	0h	☆
F8-05	Reserved			
F8-06	Module temperature threshold	0℃~100℃	75℃	☆
F8-07	Zero current detection level	0.0%~300.0%	10.0%	☆
F8-08	Zero current detection delay time	0.01s~300.00s	1.00s	☆
F8-09	Reserved			
F8-10	Reserved			
F8-11	Current detection level 1	0.0%~300.0%	100.0%	☆
F8-12	Current reached detection duration 1	0.0%~300.0%	0.0%	☆
F8-13	Current detection level 2	20.0%~300.0%	100.0%	☆
F8-14	Current reached detection duration 2	0.0%~300.0%	0.0%	☆
F8-15	Cooling fan control	0:Fan working continuously. 1:Fan working during running (Fan working after stopping when temperature is higher than 40℃) 2:Fan working when heatsink temp above 50℃	1	★
F8-16	Frequency reached detection value 1	0.00Hz~A0-00	50.00Hz	☆
F8-17	Frequency reached detection duration 1	0.0%~100.0%	0.0%	☆
F8-18	Frequency reached	0.00 Hz to maximum frequency(A0-00)	50.00Hz	☆



Function Code	Parameter Name	Setting Range	Default	Property
F8-36	Load speed display coefficient	0.001~655.00	1.000	☆
F8-37	Motor rotational display correction coefficient	0.0010~3.0000	1.0000	☆
F8-38	Linear speed display coefficient	Line speed = F8-38 * Number of HDI pulses sampled per second / Fb-08	1.000	☆
F8-39	Output power correction coefficient	0.001~3.000	1.000	☆
<b>Group F9 : Fault and Protection</b>				
F9-00	Motor overload protection selection.	0:Disable                      1:Enable	1	☆
F9-01	Motor overload protection gain	0.10~10.00	1.00	☆
F9-02	Motor overload warning coefficient	50%~100%	80%	☆
F9-03	CBC current limit	0:Disable                      1:Enable	1	☆
F9-04	Motor overload protection current coefficient	100%~200%	100%	☆
F9-05	Short-circuit to ground upon power-on	0:Disable                      1:Enable	1	☆
F9-06	Overvoltage stall gain	0 to 100	30	☆
F9-07	Overvoltage stall protective voltage	200.0~850.0V	Model dependent	★
F9-08	Overvoltage stalling allowed to rise limit value	0.0%~50.0%	10.0%	☆
F9-09	Overvoltage inhibition mode selection	0:Ineffective 1:Overvoltage inhibition mode 1 2:Overvoltage inhibition mode 2	1	★
F9-10	Threshold of over-voltage inhibition mode 2	1.0%~150.0%	100.0%	★
F9-11~ F9-13	Reserved			
F9-14	Input phase loss protection	0:Disable                      1:Enable	1	☆
F9-15	Output phase loss protection	0:Disable                      1:Enable	1	☆

## FG210 User Manual

Function Code	Parameter Name	Setting Range	Default	Property
F9-16	Undervoltage fault auto reset selection	0:Manual reset fault after the under voltage fault. 1:Auto reset fault according to the bus voltage after the fault.	0	☆
F9-17	Fault auto reset times	0 to 20	0	☆
F9-18	Time interval of fault auto reset	0.1s to 100.0s	1.0s	☆
F9-19	Fault relay action selection during fault auto reset	0:Not act                      1:Act	0	☆
F9-20	Fault protection action selection 1	0~22202 ; Unit's digit:Motor over load – Err15 0:Coast to stop 1:Stop according to stop mode 2:Continue to run Ten's digit:Reserved Hundred's digit:Input phase loss-Err12 Thousand's digit:Output phase loss-Err13 Ten thousand's digit:Parameter read-write fault-Err25	00000	☆
F9-21	Fault protection action selection 2	0~22222 ; Unit's digit:Communication fault-Err23 0:Coast to stop 1:Stop according to stop mode 2:Continue to run Ten's digit:External equipment fault -Err21 Hundred's digit:Too large speed deviation-Err19 Thousand's digit:User-definedfault1 -Err49 Ten thousand's digit:User-definedfault2-Err50	00000	☆
F9-22	Fault protection action selection 3	0~22222 ; Unit's digit:PID feedback lost during running-Err26 0:Coast to stop 1:Stop according to stop mode 2:Continue to run Ten's digit:Load becoming-Err18 Hundreds digit:reserved Thousand's digit:Current running time reached-Err30 Ten thousand's digit: Accumulative running time reached-Err31	00000	☆
F9-23	Reserved			
F9-24	Frequency selection for continuing to run upon fault	0:Current running frequency 1:Set frequency 2:Frequency upper limit 3:Frequency lower limit 4:Backup frequency(F9-25)	1	☆



Function Code	Parameter Name	Setting Range	Default	Property
F9-25	Backup frequency upon abnormality	0.0%~100.0%	100.0%	☆
F9-26	Detection value of too large speed deviation	0.0%~100.0%	20.0%	☆
F9-27	Detection time of too large speed deviation	0.0s~100.0s	0.0s	☆
F9-28	Over-speed detection value	0.0%~100.0%	20.0%	☆
F9-29	Over-speed detection time	0.0s~100.0s	2.0s	☆
F9-30~ F9-32	Reserved			
F9-33	Protection upon load becoming 0	0:Disable      1:Enable	0	☆
F9-34	Detection level of load becoming 0	0.0%~80.0%	20.0%	★
F9-35	Detection time of load becoming 0	0.0s~100.0s	5.0s	☆
<b>Group FA: PID Function</b>				
FA-00	Proportional gain Kp1	0.0 to 100.0	20.0	☆
FA-01	Integral time Ti1	0.01s to 10.00s	2.00s	☆
FA-02	Derivative time Td1	0.000s to 10.000s	0.000s	☆
FA-03	PID reference setting channel	0:Digital setting of PID (FA-07) 1:A1                      2:Reserved 3:Communication setting 4:Pulse reference      5:Multi-reference 6:Up/Down to modify FA-07( Valid when F0-03 equals 6)	0	☆
FA-04	PID feedback source	0:A1                                      1:Reserved 2:Reserved 3:Communication setting 4:Pulse reference                      5:Reserved 6:Reserved                                      7:Reserved 8:Digital setting of PID feedback(FA-09)	0	☆
FA-05	PID initial value	0.0% to 100.0%	0.0%	☆
FA-06	Hold time of PID initial value	0.00s to 650.00s	0.00s	☆
FA-07	Digital setting of PID reference	0.0% to 100.0%	50.0%	☆
FA-08	PID reference change time	0.00s to 650.00s	0.00s	☆



Function Code	Parameter Name	Setting Range	Default	Property
		0:Continue      1:Stop		
FA-28	PID operation at stop	0:No PID operation at stop 1:PID operation at stop	0	☆
FA-29	Sleep selection	0:Sleep function ineffective 1:DI terminal control 2:PID setting and feedback control 3:Running frequency control	0	☆
FA-30	Sleep frequency	0.00Hz to A0-00	0.00Hz	☆
FA-31	Sleep delay time	0.0s to 3600.0s	20.0s	☆
FA-32	Wake-up deviation	0.0% to 100.0%	10.0%	☆
FA-33	Wake-up delay time	0.0s to 3600.0s	0.5s	☆
FA-34	Sleep delay time Frequency output selection	0:PID auto-adjustment 1:Sleep frequency FA-30	0	☆
<b>Group Fb: Swing Frequency, Fixed Length and Count</b>				
Fb-00	Swing frequency setting mode	0:Relative to the center frequency 1:Relative to the maximum frequency	0	☆
Fb-01	Swing frequency amplitude	0.0% to 100.0%	0.0%	☆
Fb-02	Swing frequency cycle	0.1s to 3000.0s	10.0s	☆
Fb-03	Jump frequency amplitude	0.0% to 50.0%	0.0%	☆
Fb-04	Set length	0m to 65535m	1000m	☆
Fb-05	Actual length	0m to 65535m	0m	☆
Fb-06	Set count value	1 to 65535	1000	☆
Fb-07	Designated count value	1 to 65535	1000	☆
Fb-08	Number of pulses per meter	0.1 to 6553.5	100.0	☆
Fb-09	Triangular wave rising time coefficient	0.1% to 100.0%	50.0%	☆
<b>Group FC: Multi-Reference and Simple PLC Function</b>				
FC-00	Multi-segment frequency 0	-100.0%~100.0%	0.0%	☆
FC-01	Multi-segment frequency 1	-100.0%~100.0%	0.0%	☆
FC-02	Multi-segment frequency 2	-100.0%~100.0%	0.0%	☆

## FG210 User Manual

Function Code	Parameter Name	Setting Range	Default	Property
FC-03	Multi-segment frequency 3	-100.0%~100.0%	0.0%	☆
FC-04	Multi-segment frequency 4	-100.0%~100.0%	0.0%	☆
FC-05	Multi-segment frequency 5	-100.0%~100.0%	0.0%	☆
FC-06	Multi-segment frequency 6	-100.0%~100.0%	0.0%	☆
FC-07	Multi-segment frequency 7	-100.0%~100.0%	0.0%	☆
FC-08	Multi-segment frequency 8	-100.0%~100.0%	0.0%	☆
FC-09	Multi-segment frequency 9	-100.0%~100.0%	0.0%	☆
FC-10	Multi-segment frequency 10	-100.0%~100.0%	0.0%	☆
FC-11	Multi-segment frequency 11	-100.0%~100.0%	0.0%	☆
FC-12	Multi-segment frequency 12	-100.0%~100.0%	0.0%	☆
FC-13	Multi-segment frequency 13	-100.0%~100.0%	0.0%	☆
FC-14	Multi-segment frequency 14	-100.0%~100.0%	0.0%	☆
FC-15	Multi-segment frequency 15	-100.0%~100.0%	0.0%	☆
FC-16	Simple PLC running mode	0:Stop after running for one cycle 1:Keep final values after running for one cycle 2:Repeat after running for one cycle	0	☆
FC-17	Simple PLC memory retention	0:Non-retentive neither at power off nor after stop. 1:Retentive at power off but non-retentive after stop. 2:Non-retentive at power off but retentive after stop. 3:Retentive at power off and after stop.	0	☆
FC-18	Running time of PLC reference 0	0.0 to 6500.0	0.0	☆
FC-19	Acceleration/deceleration time of PLC reference 0	0 to 3(Respectively represents the acceleration and deceleration time 1 to 4)	0	☆

Function Code	Parameter Name	Setting Range	Default	Property
FC-20	Running time of PLC reference 1	0.0 to 6500.0	0.0	☆
FC-21	Acceleration/deceleration time of PLC reference 1	0 to 3(Respectively represents the acceleration and deceleration time 1 to 4)	0	☆
FC-22	Running time of PLC reference 2	0.0 to 6500.0	0.0	☆
FC-23	Acceleration/deceleration time of PLC reference 2	0 to 3(Respectively represents the acceleration and deceleration time 1 to 4)	0	☆
FC-24	Running time of PLC reference 3	0.0 to 6500.0	0.0	☆
FC-25	Acceleration/deceleration time of PLC reference 3	0 to 3(Respectively represents the acceleration and deceleration time 1 to 4)	0	☆
FC-26	Running time of PLC reference 4	0.0~6500.0	0.0	☆
FC-27	Acceleration/deceleration time of PLC reference 4	0 to 3(Respectively represents the acceleration and deceleration time 1 to 4)	0	☆
FC-28	Running time of PLC reference 5	0.0 to 6500.0	0.0	☆
FC-29	Acceleration/deceleration time of PLC reference 5	0 to 3(Respectively represents the acceleration and deceleration time 1 to 4)	0	☆
FC-30	Running time of PLC reference 6	0.0 to 6500.0	0.0	☆
FC-31	Acceleration/deceleration time of PLC reference 6	0 to 3(Respectively represents the acceleration and deceleration time 1 to 4)	0	☆
FC-32	Running time of PLC reference 7	0.0 to 6500.0	0.0	☆
FC-33	Acceleration/deceleration time of PLC reference 7	0 to 3(Respectively represents the acceleration and deceleration time 1 to 4)	0	☆
FC-34	Running time of PLC reference 8	0.0 to 6500.0	0.0	☆
FC-35	Acceleration/deceleration time of PLC reference 8	0 to 3(Respectively represents the acceleration and deceleration time 1 to 4)	0	☆
FC-36	Running time of PLC reference 9	0.0 to 6500.0	0.0	☆

## FG210 User Manual

Function Code	Parameter Name	Setting Range	Default	Property
FC-37	Acceleration/deceleration time of PLC reference 9	0 to 3(Respectively represents the acceleration and deceleration time 1 to 4)	0	☆
FC-38	Running time of PLC reference 10	0.0 to 6500.0	0.0	☆
FC-39	Acceleration/deceleration time of PLC reference 10	0 to 3(Respectively represents the acceleration and deceleration time 1 to 4)	0	☆
FC-40	Running time of PLC reference 11	0.0 to 6500.0	0.0	☆
FC-41	Acceleration/deceleration time of PLC reference 11	0 to 3(Respectively represents the acceleration and deceleration time 1 to 4)	0	☆
FC-42	Running time of PLC reference 12	0.0 to 6500.0	0.0	☆
FC-43	Acceleration/deceleration time of PLC reference 12	0 to 3(Respectively represents the acceleration and deceleration time 1 to 4)	0	☆
FC-44	Running time of PLC reference 13	0.0 to 6500.0	0.0	☆
FC-45	Acceleration/deceleration time of PLC reference 13	0 to 3(Respectively represents the acceleration and deceleration time 1 to 4)	0	☆
FC-46	Running time of PLC reference 14	0.0 to 6500.0	0.0	☆
FC-47	Acceleration/deceleration time of PLC reference 14	0 to 3(Respectively represents the acceleration and deceleration time 1 to 4)	0	☆
FC-48	Running time of PLC reference 15	0.0 to 6500.0	0.0	☆
FC-49	Acceleration/deceleration time of PLC reference 15	0 to 3(Respectively represents the acceleration and deceleration time 1 to 4)	0	☆
FC-50	PLC running time unit	0:s (second)                      1:h (hour)	0	☆
FC-51	Multi-Reference priority selection	0:No                                      1:Yes	1	☆
FC-52	Acceleration/deceleration time of multi-Reference	0:Acceleration/deceleration time 1 1:Acceleration/deceleration time 2 2:Acceleration/deceleration time 3 3:Acceleration/deceleration time 4	0	☆
FC-53	FC-00-FC-15 units selection of multi-segment speed	0:%                                      1:Hz	1	☆



## FG210 User Manual

Function Code	Parameter Name	Setting Range	Default	Property
FE-05	Reverse maximum frequency in torque	0.00Hz to maximum frequency(A0-00)	50.00Hz	☆
FE-06	Torque setting filter time	0.00s to 10.00s	0.00s	☆
FE-07	Acceleration time in torque control	0.0s to 1000.0s	10.0s	☆
FE-08	Deceleration time in torque control	0.0s to 1000.0s	10.0s	☆
<b>Group A0: Optimization Parameters</b>				
A0-00	Maximum output frequency	A0-02=2, 5.00Hz~599.00Hz	50.00Hz	★
A0-01	Base frequency for modification during running	0:Running frequency 1:Set frequency	1	★
A0-02	Frequency fractional selection	1:Reserved                      2:0.01Hz	2	★
A0-03~ A0-04	Reserved			
A0-05	Undervoltage threshold	170.0V to 500.0V	AB,A2:170 A4:350	☆
A0-06	Braking threshold	330.0V to 800.0V	AB,A2:360 A4:690	☆
A0-07	Deadband compensation	0:Disabled                      1:Enabled	1	☆
A0-08	Carrier frequency	0.5kHz~16kHz	Model dependent	☆
A0-09	Carrier frequency adjustment with temperature	0:No                              1:Yes	1	☆
A0-10	PWM modulation mode	0:Asynchronous modulation 1:Synchronous modulation	0	☆
A0-11	PWM seven phase/five phase selection	0:Seven phase in whole course 1:Seven phase/five phase auto switchover	0	☆
A0-12	Over modulation voltage boost	0%~10%	3%	★
A0-13	Random PWM depth	0 to 6	0	☆
A0-14	Limitation of low frequency carrier	0:Limitation mode 0 1:Limitation mode 1	0	☆



Function Code	Parameter Name	Setting Range		Default	Property
		2:Unlimited (the carrier waves are in accordance in every frequency ranges)			
<b>Group A1: Master-slave Control Parameters</b>					
A1-00	Master-slave control selection	0:Disable	1:Enable	0	★
A1-01	Master-slave selection	0:Master	1:Slave	0	★
A1-02	Master sending frequency selection	0:Running frequency	1:Target frequency	0	★
A1-03	Command source selection of slave followed the master	0:Non-follow	1:Follow	0	★
A1-04	Slave received frequency coefficient	0.00% to 600.00%		100.00%	☆
A1-05	Slave received torque coefficient	-10.00 to 10.00		1.00	☆
A1-06	Slave received torque offset	-50.00% to 50.00%		0.00%	☆
A1-07	Frequency offset threshold	0.20% to 10.00%		0.50%	☆
A1-08	Master-slave communication offline detection time	0.0s to 10.0s		0.1s	☆
<b>Group A2: Braking Function Parameters</b>					
A2-00	Braking control selection	0:Disable	1:Enable	0	★
A2-01	Reverse start positive torque enable	0:Disable	1:Enable	0	★
A2-02	Holding brake release over zero jump frequency	0.00Hz to 20.00 Hz(Valid only when A2-01=1)		1.50Hz	★
A2-03	Holding brake release current detection value	0.0% to 200.0%		20%	★
A2-04	Holding brake release frequency value	0.00Hz to 20.00 Hz		1.50Hz	★
A2-05	Delay time before holding brake release	0.0s to 20.0s		0.0s	★
A2-06	Delay time after holding brake release	0.0s to 20.0s		0.0s	★
A2-07	Holding brake closing frequency value	0.00Hz to 20.00 Hz		1.50Hz	★

## FG210 User Manual

Function Code	Parameter Name	Setting Range	Default	Property
A2-08	Delay time before holding brake closing	0.0s to 20.0s	0.0s	★
A2-09	Delay time after holding brake closing	0.0s to 20.0s	0.3s	★
A2-10	Current limit value during holding brake clamping	50.0% to 200.0%	120%	★
<b>Group A3: AI/AO Correction</b>				
A3-00	AI1 displayed voltage 1	-9.999V~10.000V	3.000V	☆
A3-01	AI1 measured voltage 1	-9.999V~10.000V	3.000V	☆
A3-02	AI1 displayed voltage 2	-9.999V~10.000V	8.000V	☆
A3-03	AI1 measured voltage 2	-9.999V~10.000V	8.000V	☆
A3-04~ A3-11	Reserved			
A3-12	AO1 target voltage 1	-9.999V~10.000V	3.000V	☆
A3-13	AO1 measured voltage 1	-9.999V~10.000V	3.000V	☆
A3-14	AO1 target voltage 2	-9.999V~10.000V	8.000V	☆
A3-15	AO1 measured voltage 2	-9.999V~10.000V	8.000V	☆
A3-16~ A3-19	Reserved			
A3-20	AI1 displayed current 1	0.000V~10.000V	3.000V	☆
A3-21	AI1 measured current 1	0.000V~10.000V	3.000V	☆
A3-22	AI1 displayed current 2	0.000V~10.000V	8.000V	☆
A3-23	AI1 measured current 2	0.000V~10.000V	8.000V	☆
A3-24~ A3-31	Reserved			
A3-32	AO1 target current 1	0.000V~20.000mA	6.000mA	☆

Function Code	Parameter Name	Setting Range	Default	Property
A3-33	AO1 measured current 1	0.000V~20.000mA	6.000mA	☆
A3-34	AO1 target current 2	0.000V~20.000mA	16.000mA	☆
A3-35	AO1 measured current 2	0.000V~20.000mA	16.000mA	☆
<b>Group A4: system parameters</b>				
A4-00	Performance software version	Performance software version number	###	●
A4-01	Function software version	Version of the performance software	###	●
A4-02	G/P type select	0:G type                      1:P type	0	★
A4-03	Rated drive current	0/1...3000A	Model dependent	●
A4-04	Product model	Display product model	###	●
A4-05	Initialization parameters	0:No operation 1:Restore factory parameters, except motor parameters, record information and A0-02 2:Clear the record information 027:Backup the current user parameters 047:User parameter backup recovery 067:Parameter upload 087:Parameter download	0	★
A4-06	Rated voltage of AC drive	220V to 400V	Model dependent	●
<b>GroupA5: User - defined Parameters</b>				
A5-00	Clear user-defined parameters	0:Disable                      1:Enable	0	☆
A5-01	User-defined parameters 1	uF0-00 to uU1-xx	uF0-03	☆
A5-02	User-defined parameters 2	uF0-00 to uU1-xx	uF0-04	☆
A5-03	User-defined parameters 3	uF0-00 to uU1-xx	uF0-06	☆
A5-04	User-defined parameters 4	uF0-00 to uU1-xx	uF0-23	☆
A5-05	User-defined parameters 5	uF0-00 to uU1-xx	uF0-24	☆
A5-06	User-defined parameters 6	uF0-00 to uU1-xx	uF4-00	☆
A5-07	User-defined parameters 7	uF0-00 to uU1-xx	uF4-01	☆

## FG210 User Manual

Function Code	Parameter Name	Setting Range	Default	Property
A5-08	User-defined parameters 8	uF0-00 to uU1-xx	uF4-02	☆
A5-09	User-defined parameters 9	uF0-00 to uU1-xx	uF4-04	☆
A5-10	User-defined parameters 10	uF0-00 to uU1-xx	uF4-05	☆
A5-11	User-defined parameters 11	uF0-00 to uU1-xx	uF4-06	☆
A5-12	User-defined parameters 12	uF0-00 to uU1-xx	uF4-12	☆
A5-13	User-defined parameters 13	uF0-00 to uU1-xx	uF4-13	☆
A5-14	User-defined parameters 14	uF0-00 to uU1-xx	uF5-00	☆
A5-15	User-defined parameters 15	uF0-00 to uU1-xx	uF5-01	☆
A5-16	User-defined parameters 16	uF0-00 to uU1-xx	uF5-02	☆
A5-17	User-defined parameters 17	uF0-00 to uU1-xx	uF6-00	☆
A5-18	User-defined parameters 18	uF0-00 to uU1-xx	uF6-01	☆
A5-19	User-defined parameters 19	uF0-00 to uU1-xx	uF0-00	☆
A5-20	User-defined parameters 20	uF0-00 to uU1-xx	uF0-00	☆
A5-21	User-defined parameters 21	uF0-00 to uU1-xx	uF0-00	☆
A5-22	User-defined parameters 22	uF0-00 to uU1-xx	uF0-00	☆
A5-23	User-defined parameters 23	uF0-00 to uU1-xx	uF0-00	☆
A5-24	User-defined parameters 24	uF0-00 to uU1-xx	uF0-00	☆
A5-25	User-defined parameters 25	uF0-00 to uU1-xx	uF0-00	☆
A5-26	User-defined parameters 26	uF0-00 to uU1-xx	uF0-00	☆
A5-27	User-defined parameters 27	uF0-00 to uU1-xx	uF0-00	☆

Function Code	Parameter Name	Setting Range	Default	Property
A5-28	User-defined parameters 28	uF0-00 to uU1-xx	uF0-00	☆
A5-29	User-defined parameters 29	uF0-00 to uU1-xx	uF0-00	☆
A5-30	User-defined parameters 30	uF0-00 to uU1-xx	uF0-00	☆
A5-31	User-defined parameters 31	uF0-00 to uU1-xx	uF0-00	☆
<b>Group A6: AI Curve Setting</b>				
A6-00	AI curve 1 minimum input	-10.00V to A6-02	0.00V	☆
A6-01	Corresponding setting of AI curve 1 minimum input	-100.0% to 100.0%	0.0%	☆
A6-02	AI curve 1 inflexion 1 input	A6-00 to A6-04	3.00V	☆
A6-03	Corresponding setting of AI curve 1 inflexion 1 input	-100.0% to 100.0%	30.0%	☆
A6-04	AI curve 1 inflexion 2 input	A6-02 to A6-06	6.00V	☆
A6-05	Corresponding setting of AI curve 1 inflexion 2 input	-100.0% to 100.0%	60.0%	☆
A6-06	AI curve 1 maximum input	A6-04 to 10.00V	10.00V	☆
A6-07	Corresponding setting of AI curve 1 maximum input	-100.0% to 100.0%	100.0%	☆
A6-08	AI curve 2 minimum input	-10.00V to A6-10	0.00V	☆
A6-09	Corresponding setting of AI curve 2 minimum input	-100.0% to 100.0%	0.0%	☆
A6-10	AI curve 2 inflexion 1 input	A6-08 to A6-12	3.00V	☆
A6-11	Corresponding setting of AI curve 2 inflexion 1 input	-100.0% to 100.0%	30.0%	☆
A6-12	AI curve 2 inflexion 2 input	A6-10 to A6-14	6.00V	☆
A6-13	Corresponding setting	-100.0% to 100.0%	60.0%	☆

## FG210 User Manual

Function Code	Parameter Name	Setting Range	Default	Property
	of AI curve 2 inflexion 2 input			
A6-14	AI curve 2 maximum input	A6-12 to 10.00V	10.00V	☆
A6-15	Corresponding setting of AI curve 2 maximum input	-100.0% to 100.0%	100.0%	☆
A6-16~ A6-23	Reserved			
A6-24	Jump point of AI1 input corresponding setting	-100.0% to 100.0%	0.0%	☆
A6-25	Jump amplitude of AI1 input corresponding setting	0.0% to 100.0%	0.5%	☆
<b>Group AA: Virtual DI/DO</b>				
AA-00	VDI1 function selection	See 5.2 DI function selection table	0	★
AA-01	VDI2 function selection		0	★
AA-02	VDI3 function selection		0	★
AA-03	VDI4 function selection		0	★
AA-04	Reserved		0	★
AA-05	VDI active state setting mode	0000~1111	0	★
AA-06	Selection of VDI active state	0000~1111	0	☆
AA-07~ AA-10	Reserved			
AA-11	VDO1 function selection	See 5.3 DO function selection table	0	★
AA-12	VDO2 function selection		0	★
AA-13	VDO3 function selection		0	★
AA-14	VDO4 function selection		0	★
AA-15	Reserved		0	★

Function Code	Parameter Name	Setting Range	Default	Property
AA-16	VDO1 close delay	0.0s to 3600.0s	0.0s	☆
AA-17	VDO2 close delay	0.0s to 3600.0s	0.0s	☆
AA-18	VDO3 close delay	0.0s to 3600.0s	0.0s	☆
AA-19	VDO4 close delay	0.0s to 3600.0s	0.0s	☆
AA-20	Reserved			☆
AA-21	VDO active mode selection	0000to 1111	00000	☆
AA-22	VDO1 open delay	0.0s to 3600.0s	0.0s	☆
AA-23	VDO2 open delay	0.0s to 3600.0s	0.0s	☆
AA-24	VDO3 open delay	0.0s to 3600.0s	0.0s	☆
AA-25	VDO4 open delay	0.0s to 3600.0s	0.0s	☆

Function Code	Parameter Name	Unit	Property
<b>Group U0: Error Recording Parameters</b>			
U0-00	3rd (latest) fault type	1	●
U0-01	2rd (latest) fault type		

## FG210 User Manual

Function Code	Parameter Name		Unit	Property
U0-02	1nd fault type	Err15:Motor overload Err16:Current detection fault Err17:Drive overheat Err18:Load becoming 0 Err19:Too large speed deviation Err20:Short circuit to ground Err21:External equipment fault Err22:Fast current limit fault Err23:Communication fault Err24:Master slave control communication disconnection Err25:EEPROM read-write fault Err26:PID feedback lost during running Err27:EEPROM storage fault Err28:Control power supply fault Err29:Motor switchover error during running Err30:Current running time reached Err31:Accumulative running time reached Err32:Motor auto-tuning fault Err33:Motor over-speed Err49>User-definedfault1 Err50>User-definedfault2	1	●
U0-03	Frequency upon the 3rd fault		0.01Hz	●
U0-04	Current upon the 3rd fault		0.01A	●
U0-05	Bus voltage upon the 3rd fault		0.1V	●
U0-06	DI status upon the 3rd fault		1	●
U0-07	Output terminal status upon the 3rd fault		1	●
U0-08	AC drive status upon the 3rd fault		1	●
U0-09	Power-on time upon the 3rd fault		1min	●
U0-10	Running time upon the 3rd fault		1min	●
U0-11	Frequency upon the 2nd fault		0.01Hz	●
U0-12	Current upon the 2nd fault		0.01A	●
U0-13	Bus voltage upon the 2nd fault		0.1V	●
U0-14	DI status upon the 2nd fault		1	●
U0-15	Frequency upon the 2nd fault		1	●
U0-16	Current upon the 2nd fault		1	●
U0-17	Bus voltage upon the 2nd fault		1min	●



Function Code	Parameter Name	Unit	Property
U0-18	DI status upon the 2nd fault	1min	●
U0-19	Frequency upon the 2nd fault	0.01Hz	●
U0-20	Current upon the 2nd fault	0.01A	●
U0-21	Bus voltage upon the 1st fault	0.1V	●
U0-22	DI status upon the 1st fault	1	●
U0-23	Output terminal status upon the 1st fault	1	●
U0-24	AC drive status upon the 1st fault	1	●
U0-25	Power-on time upon the 1st fault	1min	●
U0-26	Running time upon the 1st fault	1min	●
<b>Group U1: Application Monitoring Parameters</b>			
U1-00	Running frequency(Hz)	0.01Hz	●
U1-01	Setting frequency(Hz)	0.01Hz	●
U1-02	Bus voltage(V)	0.1V	●
U1-03	Output voltage(V)	1V	●
U1-04	Output current(A)	0.1A	●
U1-05	Output power(kW)	0.1kW	●
U1-06	DI input status, hexadecimal	1	●
U1-07	DO output status, hexadecimal	1	●
U1-08	Target torque	0.1%	●
U1-09	Output torque	0.1%	●
U1-10	Torque upper limit	0.1%	●
U1-11	Output torque	0.1%	●
U1-12	AI1 voltage after correction	0.01V	●
U1-13	Reserved	0.01V	●
U1-14	PID setting, PID setting ( percentage)*FA-10	1	●
U1-15	PID feedback, PID feedback ( percentage)*FA-10	1	●

## FG210 User Manual

Function Code	Parameter Name	Unit	Property
U1-16	Count value	1	●
U1-17	Length value	1	●
U1-18	Motor speed	rpm	●
U1-19	Feedback speed	0.1Hz	●
U1-20	Load speed display	User Defined	●
U1-21	PLC stage	1	●
U1-22	Communication setting value	0.01%	●
U1-23	Main frequency X	0.01Hz	●
U1-24	Auxiliary frequency Y	0.01Hz	●
U1-25	Input pulse frequency	0.01kHz	●
U1-26	Pulse input frequency	1Hz	●
U1-27	DI4 high speed pulse sampling linear speed	1m/min	●
U1-28	AI1 voltage before correction	0.001V	●
U1-29	Reserved	0.001V	●
U1-30	Target voltage upon V/F separation	1V	●
U1-31	Output voltage upon V/F separation	1V	●
U1-32	AO1 target voltage	0.01V	●
U1-33	Reserved	0.01V	●
U1-34	Current motor number	1	●
U1-35	AC input current	0.1A	●
U1-36	AC drive running status:0:Stop 2:Reverse            1:Forward 3:Fault	1	●
U1-37	AC drive current fault	1	●
U1-38	Current power-on time	1min	●
U1-39	Current running time	0.1min	●
U1-40	Agent remaining limited time	1h	●

<b>Function Code</b>	<b>Parameter Name</b>	<b>Unit</b>	<b>Property</b>
U1-41	Remaining running time of F8-28 setting	0.1min	●
U1-42	PLC current stage remaining time	0.1	●
U1-43	Accumulative running time 1(Accumulative running time=U1-43+U1-44)	1h	●
U1-44	Accumulative running time 2 (Accumulative running time=U1-43+U1-44)	1min	●
U1-45	Motor temperature	1℃	●
U1-46	Temperature of AC drive module	1℃	●
U1-47	Accumulative power-on time	1h	●
U1-48	Accumulative power consumption	1kWh	●
U1-49	Set the middle value of frequency	0.01Hz	●

**5.2 DI function selection**

DI Setting Value	Function	DI Setting Value	Function	DI Setting Value	Function
0	No function	18	Frequency source switchover	36	External STOP terminal1
1	Forward RUN (FWD)	19	UP and DOWN setting clear (terminal, operation panel)	37	Command source switchover terminal 2
2	Reverse RUN (REV)	20	Command source switchover terminal 1	38	PID integral disabled
3	Three-wire control	21	Acceleration/Deceleration prohibited	39	Switchover between main frequency source X and preset frequency
4	Forward JOG (FJOG)	22	PID pause	40	Switchover between auxiliary frequency source Y and preset frequency
5	Reverse JOG (RJOG)	23	PLC status reset	41	Reserved
6	Terminal UP	24	Swing pause	42	Reserved
7	Terminal DOWN	25	Timer trigger input	43	PID parameter switchover
8	Coast to stop	26	Immediate DC injection braking	44	Speed control/Torque control switchover
9	Fault reset (RES)	27	External fault normally closed (NC) input	45	Reserved
10	RUN pause	28	Counter input	46	External STOP terminal 2
11	External fault normally open (ON) input	29	Counter reset	47	Deceleration DC injection braking
12	Multi-reference terminal 1	30	Length count input	48	Clear the current running time
13	Multi-reference terminal 2	31	Length count reset	49	Two-wire/three-wire control mode switchove
14	Multi-reference terminal 3	32	Torque control prohibited	50	Reverse run prohibited
15	Multi-reference terminal 4	33	Pulse input (enabled only for DI5)	51	User- defined fault 1
16	Terminal 1 for acceleration/deceleration time selection	34	Frequency modification forbidden	52	User-defined fault 2
17	Terminal 2 for acceleration/deceleration time selection	35	PID action direction reverses	53	PID sleep

5.3 DO function selection

DO Setting Value	Function	DO Setting Value	Function	DO Setting Value	Function
0	No output	16	Communication setting	32	Brake control output
1	AC drive running	17	Timer output	33	Zero-speed running 2 (having output at stop)
2	Fault output	18	Reverse running	34	Frequency level detection FDT2 output
3	Frequency-level detection FDT1 reached	19	Reserved	35	Zero current state
4	Frequency reached(FAR)	20	Length reached	36	Software over current
5	Zero-speed running (no output at stop)	21	Torque limited	37	Frequency lower limit reached (having output at stop)
6	Motor overload pre-warning	22	Current 1 reached	38	Alarm output
7	AC drive overload pre-warning	23	Frequency 1 reached	39	Reserved
8	PLC cycle completed	24	Module temperature reached	40	AI1 input overrun
9	Accumulative running time reached	25	Load lost	41	Reserved
10	Pendulum frequency is limited	26	Accumulative power-on time reached	42	Reserved
11	Ready for RUN	27	Clocking reached output	43	Frequency 2 reached
12	AI1>AI2	28	Current running time reached	44	Current 2 reached
13	Frequency upper limit reached	29	Set count value reached	45	Fault output
14	Frequency lower limit reached	30	Designated count value reached		
15	Undervoltage state output	31	Motor 1 and motor 2 indication		

## Chapter 6 Trouble Shooting

If a fault occurs during the system operation, the drive will immediately protect the motor to stop the output, and the corresponding drive fault relay contact will act. The drive panel displays the fault code. The fault type and common solution corresponding to the fault code are shown in the following table. The list in the table is for reference only, please do not repair or modify it without authorization. If the fault cannot be eliminated, please seek technical support from our company or the product agent.

### 6.1 Faults and Solutions

Display	Fault Name	Possible Causes	Solutions
Err01	AC drive unit protection	1:Whether the motor connection terminals U, V, W have short-circuit or straight-through between phases or to ground 2:Whether the module is overheating 3:Whether the internal wiring of the drive is loose 4:Whether the main control board, driver board or module is normal	1:Check motor wiring and output impedance to ground 2:Check whether the fan and air duct are normal 3:Connect all loose wires 4:Seek technical support
Err02	Overcurrent during acceleration	1:The output circuit is grounded or short circuited 2:Motor parameter is not right 3:The acceleration time is too short 4:Manual torque boost or V/F curve is not appropriate 5:The voltage is too low 6:The startup operation is performed on the rotating motor 7:A sudden load is added during acceleration 8:The AC drive model is of too small	1:Eliminate external faults 2:Perform the motor auto-tuning 3:Increase the acceleration time 4:Correctly set the V/f curve 5:Check grid input power 6>Select rotational speed tracking restart or start the motor after it stops 7:Remove the added load 8>Select an AC drive of higher power class
Err03	Overcurrent during deceleration	1:The output circuit is grounded or short circuited 2:Motor parameter is not right 3:The deceleration time is too short 4:The voltage is too low 5:A sudden load is added during deceleration 6:The inertia of the load is too large 7:The magnetic flux braking gain is too large	1:Eliminate external faults 2:Perform the motor auto-tuning 3:Increase the deceleration time 4:Adjust the voltage to normal range 5:Remove the added load 6:Install the braking unit and braking resistor 7:decrease the over-excitation gain

Err04	Over current at constant speed	<ol style="list-style-type: none"> <li>1:The output circuit is grounded or short circuited</li> <li>2:Motor parameter is not right.</li> <li>3:The voltage is too low</li> <li>4:A sudden load is added during operation</li> <li>5:The AC drive model is of too small</li> </ol>	<ol style="list-style-type: none"> <li>1:Eliminate external faults</li> <li>2:Perform the motor auto-tuning</li> <li>3:Adjust the voltage to normal range</li> <li>4:Remove the added load</li> <li>5:Select an AC drive of higher power class</li> </ol>
Err08	Overtoltage during acceleration	<ol style="list-style-type: none"> <li>1:The input voltage is too high</li> <li>2:An external force drives the motor during acceleration</li> <li>3:The acceleration time is too short</li> <li>4:The inertia of the load is too large</li> <li>5:Motor parameter is not right</li> </ol>	<ol style="list-style-type: none"> <li>1:Adjust the voltage to normal range</li> <li>2:Cancel the external force or install a braking resistor</li> <li>3:Extend the acceleration time</li> <li>4:Use energy consumption braking</li> <li>5:Auto-tune the parameters of the motor</li> </ol>
Err09	Overtoltage during deceleration	<ol style="list-style-type: none"> <li>1:The input voltage is too high</li> <li>2:An external force drives the motor during deceleration</li> <li>3:The deceleration time is too short.</li> <li>4:The inertia of the load is too large</li> </ol>	<ol style="list-style-type: none"> <li>1:Adjust the voltage to normal range</li> <li>2:Cancel the external force or install a braking resistor</li> <li>3:Increase the deceleration time</li> <li>4:Install the braking unit and braking resistor</li> </ol>
Err10	Overtoltage at constant speed	<ol style="list-style-type: none"> <li>1:The input voltage is too high</li> <li>2:An external force drives the motor during acceleration</li> <li>3:When the vector control is running, the parameters of the regulator are not set properly</li> <li>4:The load fluctuates too much</li> </ol>	<ol style="list-style-type: none"> <li>1:Adjust the voltage to normal range</li> <li>2:Cancel the external force or install a braking resistor</li> <li>3:Correctly set the regulator parameters</li> <li>4:Check the load</li> </ol>
Err11	Undervoltage	<ol style="list-style-type: none"> <li>1:Instantaneous power failure occurs</li> <li>2:The input voltage exceeds the allowed range</li> <li>3:The DC bus voltage is too low</li> <li>4:The rectifier bridge and buffer resistor are faulty</li> <li>5:The drive board is faulty</li> <li>6:The control board is faulty</li> </ol>	<ol style="list-style-type: none"> <li>1:Reset the fault</li> <li>2:Adjust the input voltage to within the allowed range</li> <li>3:Seek for maintenance</li> </ol>
Err12	Power input phase loss	<ol style="list-style-type: none"> <li>1:The three-phase power input is abnormal</li> <li>2:The drive board is faulty</li> <li>3:The lightening board is faulty</li> <li>4:The main control board is faulty</li> </ol>	<ol style="list-style-type: none"> <li>1:Eliminate external faults</li> <li>2:Seek for maintenance</li> </ol>

Err13	Power output phase loss	<ol style="list-style-type: none"> <li>1:The cable connecting the AC drive and the motor is faulty</li> <li>2:The AC drive's three-phase outputs are unbalanced when the motor is running</li> <li>3:The drive board is faulty</li> <li>4:The module is faulty</li> </ol>	<ol style="list-style-type: none"> <li>1:Eliminate external faults</li> <li>2:Check the motor or replace the motor</li> <li>3:Seek for maintenance</li> </ol>
Err14	Drive overload	<ol style="list-style-type: none"> <li>1:The torque boost value is too large during V/f control</li> <li>2:The starting frequency is too high</li> <li>3:The acceleration and deceleration time is too short</li> <li>4:Improper setting of motor parameters</li> <li>5:Overload</li> <li>6:The V/f curve is not suitable for V/f control</li> <li>7:Restart the rotating motor</li> <li>8:Output phase-to-phase short-circuit or short-circuit to ground</li> </ol>	<ol style="list-style-type: none"> <li>1:Reduce the torque boost value</li> <li>2:Reduce the starting frequency value</li> <li>3:Extend the acceleration and deceleration time</li> <li>4:Correctly set according to the motor nameplate</li> <li>5:Lighten the load</li> <li>6:Correctly set the V/f curve</li> <li>7:Reduce the current limit value or start by speed search</li> <li>8:Check the motor wiring and output impedance to ground</li> </ol>
Err15	Motor overload	<ol style="list-style-type: none"> <li>1:Whether the setting of motor protection parameter F9-01 is appropriate</li> <li>2:Whether the load is too large or the motor is blocked</li> <li>3:Drive selection is too small</li> <li>4:The torque boost value is too large during V/f control</li> <li>5:The V/f curve is not suitable for V/f control</li> <li>6:Improper setting of motor parameters</li> <li>7:Improper setting of motor overload protection time</li> <li>8:Motor stall or load sudden change is too large</li> </ol>	<ol style="list-style-type: none"> <li>1:Set this parameter correctly</li> <li>2:Reduce the load and check the motor and mechanical condition</li> <li>3:Choose driver with larger power level</li> <li>4:reduce the torque to increase the value</li> <li>5:Set V/ F curve correctly</li> <li>6:Set correctly according to the motor nameplate</li> <li>7:Set the motor overload protection time correctly</li> <li>8:Check the cause of motor blocking or check the load</li> </ol>
Err16	Current detection fault	<ol style="list-style-type: none"> <li>1:The internal connections become loose</li> <li>2:Confirm whether the current detection device is normal</li> <li>3:The control or drive board is faulty</li> </ol>	<ol style="list-style-type: none"> <li>1:Connect all cables properly.</li> <li>2:Seek for maintenance</li> </ol>



Err17	Drive temperature exceeds the limit	1:The ambient temperature is too high 2:The air filter is blocked 3:The cooling fan is damaged 4:The thermally sensitive resistor of the module is damaged 5:The inverter module is damaged. 6:The temperature sensor is improperly connected	1:Lower the ambient temperature 2:Clean the air filter 3:Replace the damaged fan 4:Replace the damaged thermally sensitive resistor 5:Replace the inverter module 6:Seek service
Err18	Load becoming 0	The detection is reached, get more details form F9-33 to F9-35.	Reset the fault or reset F9-33 to F9-35 value
Err19	Too large speed deviation	1:The load is too heavy and the acceleration time is too short 2:F9-26 and F9-27 are set incorrectly 3:The set value of the deviation between the motor speed and the set speed is too small 4:The load fluctuates too much 5:The control parameter setting of vector control is unreasonable	1:Increase the acceleration and deceleration time 2:Set F9-26 and F9-27 correctly based on the actual situation 3:Correctly set the speed deviation point 4:Stable load 5:Correct settings
Err20	Short circuit to ground	1:The motor is short circuited to the ground 2:The output wiring is short-circuited to ground 3:Abnormal motor insulation 4:The inverter module is abnormal 5:The output leakage current to the ground is too large	1:Replace the cable or motor 2:Check the motor wiring and output impedance to ground 3:Check the motor 4:Seek service
Err21	External equipment fault	External fault normally closed or normally open signal is input via DI	Reset the fault
Err22	Fast current limit fault	1:The load is too heavy or the rotor is locked 2:The acceleration time is too short	1:Reduce load or replace with higher power drive 2:Increase the acceleration time
Err23	Communication fault	1:The host computer is in abnormal state 2:The communication cable is faulty 3:The communication parameters in group Fd are set improperly	1:Check cabling of the host computer 2:Check the communication cabling 3:Check Fd group parameters
Err24	Master-Slave Communication Dropout	1:Not set the host but set the slave 2:Communication cable abnormality or incorrect communication parameters	1:Set the host and reset the fault 2:check the communication line and communication parameters Fd group
Err25	EEPROM read-write fault	The EEPROM chip is damaged	Replace the main control board

## FG210 User Manual

Err26	PID feedback lost during running	1:The PID feedback is lower than the setting of FA-16 2:The PID feedback channel is abnormal 3:PID parameter setting is unreasonable	1:Check the PID feedback signal or set FA-16 to a proper value 2:Check the feedback channel 3:Correct settings
Err27	Data storage fault	Communication between DSP and EEPROM fault	1:Replace the main control board 2:Seek service
Err28	Control power supply fault	1:The input voltage is not within the allowable range 2:The power on and off is too frequently	1:Adjust the input voltage to the allowable range 2:Extension of power on cycle
Err30	Accumulative running time reached	The accumulative running time reaches the setting value of F8-31.	Reset the fault
Err31	Cumulative running time reached	U1-43 Accumulated runtime > F8-28 set value	Reset the fault
Err32	Tuning Faults	1:Motor parameters are not set according to the nameplate 2:Parameter identification process timeout 3:Encoder abnormality	1:According to the motor nameplate parameter setting 2:Check the AC drive and motor wiring 3:Check whether the encoder parameter setting is correct or not.
Err33	Motor overspeed	1:Is the encoder parameter setting correct 2:Is the parameter identification 3:Fault detection parameters F9-28, F9-29 set unreasonable	1:Correctly set the encoder parameters 2:Motor parameter identification 3:Reasonable setting of fault detection parameters
Err49	User-defined fault 1	The user-defined fault 1 signal is input via DI	Reset the fault
Err50	User-defined fault 2	The user-defined fault 2 signal is input via DI	Reset the fault

**6.2 Common Symptoms and Diagnostics**

The following fault conditions may be encountered during the use of the drive, please refer to the following methods for simple fault analysis.

NO.	Fault Name	Possible Causes	Solutions
1	There is no display at power-on.	1:There is no power supply or the power supply is too low 2:The switching power supply on the drive board is faulty 3:The rectifier bridge is damaged 4:The buffer resistor of the drive is damaged 5:The control board or the keypad is faulty 6:The cable between the control board and the drive board or keypad breaks	1:Check the power supply 2:Check the bus voltage 3:Re-connect the keypad and core cables 4:Seek service
2	"Err20" is displayed at power-on	1:The motor or the motor output cable is short-circuited to the ground 2:The AC driver is damage	1:Measure the insulation of the motor and the output cable with a megger. 2:Seek service
3	Err17 (Drive temperature exceeds the limit)	1:The setting of carrier frequency is too high 2:The cooling fan is damaged, or the air filter is blocked 3:Components inside the AC drive are damaged (thermal coupler or others)	1:Reduce the carrier frequency (F0-16). 2:Replace the fan and clean the air filter 3:Seek service
4	The motor does not rotate after the AC drive runs.	1:Check the motor and the motor cables 2:The AC drive parameters are set improperly (motor parameters) 3:The cable between the drive board and the control board is in poor contact 4:The drive board is faulty	1:Ensure the cable between the AC drive and the motor is normal 2:Replace the motor or clear mechanical faults 3:Check and re-set motor parameters
5	The DI terminals are disabled.	1:The parameters are set incorrectly 2:The external signal is incorrect 3:The DI DIP switch is in the wrong position 4:The control board is faulty	1:Check and reset the parameters in group F5 2:Re-connect the external signal cables 3:Re-confirm whether the position of the DI DIP switch is consistent with the wiring method 4:Seek service
6	The AC drive reports over-current and over-voltage frequently	1:The motor parameters are set improperly 2:The acceleration/deceleration time is improper 3:The load fluctuates	1:Re-set motor parameters or re-perform the motor auto-tuning 2:Set proper acceleration/ deceleration time 3:Seek service

# Chapter 7 Maintenance

Affected by the ambient temperature, humidity, dust, vibration and the aging of the internal components of the drive, some potential problems may occur during the operation of the drive. The AC drive conducts daily inspections and periodic inspections. Depending on the external environment of the drive, regular maintenance must be carried out every 3 to 6 months, so as to discover and deal with the problems that are difficult to find in the routine inspection process in time.

## 7.1 Daily inspection

To avoid damage to the drive and shorten its service life, please check the following items daily.

Inspection items	Check the content	Measures
Motor	<ul style="list-style-type: none"> <li>● Whether the motor has abnormal vibration and abnormal sound</li> </ul>	<ul style="list-style-type: none"> <li>● Confirm whether the mechanical connection is abnormal</li> <li>● Confirm whether the motor is out of phase</li> <li>● Confirm that the motor fixing screws are secure</li> </ul>
Fan	<ul style="list-style-type: none"> <li>● Abnormal use of drive and motor cooling fan</li> </ul>	<ul style="list-style-type: none"> <li>● Confirm whether the cooling fan of the drive is running</li> <li>● Confirm whether the cooling fan on the motor side is abnormal</li> <li>● Confirm whether the ventilation channel is blocked</li> <li>● Check that the ambient temperature is within the allowable range</li> </ul>
Installation Environment	<ul style="list-style-type: none"> <li>● Whether the electrical cabinet and cable trough are abnormal</li> </ul>	<ul style="list-style-type: none"> <li>● Check whether the insulation of the cables entering or leaving the drive is damaged</li> <li>● Determine whether there is vibration on the mounting bracket</li> <li>● Check whether the copper bars and connecting cable terminals are loose and corroded</li> </ul>
Load	<ul style="list-style-type: none"> <li>● Whether the drive running current exceeds the drive rating and motor rating for a certain period of time</li> </ul>	<ul style="list-style-type: none"> <li>● Confirm whether the motor parameters are set correctly</li> <li>● Confirm whether the motor is overloaded</li> <li>● Confirm whether the mechanical vibration is too large (normal condition &lt;0.6g)</li> </ul>
Power supply	<ul style="list-style-type: none"> <li>● Whether the input voltage meets the requirements and whether there is a lack of phase power supply</li> </ul>	<ul style="list-style-type: none"> <li>● Confirm whether the voltage between any two phases of the input voltage is within the allowable range indicated on the nameplate</li> <li>● Check if there is a large load around to start</li> </ul>

## 7.2 Regular Maintenance

Under normal circumstances, it is advisable to conduct regular inspections every 3 months to 6 months, but in actual cases, please determine the actual inspection cycle based on the usage and working environment of each machine.

Inspection items	Check the content	Measures
Complete machine	<ul style="list-style-type: none"> <li>● Whether there is garbage, dirt, dust accumulation on the surface</li> </ul>	<ul style="list-style-type: none"> <li>● Confirm whether the drive cabinet is powered off</li> <li>● Use a vacuum cleaner to remove rubbish or dust to avoid touching the parts</li> <li>● When the surface dirt cannot be removed, can use alcohol to wipe it and wait for it to dry and evaporate completely</li> </ul>
Air duct vent	<ul style="list-style-type: none"> <li>● Whether the air duct and heat sink are blocked</li> <li>● Whether the fan is damaged</li> </ul>	<ul style="list-style-type: none"> <li>● Clean the air duct</li> <li>● Replace the fan</li> </ul>
Electrical connections	<ul style="list-style-type: none"> <li>● Whether there is discoloration of wires and connection parts, and whether the insulation layer is damaged, cracked, discolored and aging</li> <li>● Whether the connecting terminals are worn, damaged or loose</li> <li>● Ground check</li> </ul>	<ul style="list-style-type: none"> <li>● Replace damaged cables</li> <li>● Tighten loose terminals and replace damaged terminals</li> <li>● Measure the grounding resistance and fasten the corresponding grounding terminal</li> </ul>
Magnetic contactor periphery	<ul style="list-style-type: none"> <li>● Whether the suction is not firm or makes abnormal noise during action</li> <li>● Whether there are short-circuited, water-stained, swollen, or ruptured peripheral devices</li> </ul>	<ul style="list-style-type: none"> <li>● Replace defective components</li> </ul>
Motor	<ul style="list-style-type: none"> <li>● Whether the motor has abnormal vibration and abnormal noise</li> </ul>	<ul style="list-style-type: none"> <li>● Tighten mechanical and electrical connections and lubricate motor shaft</li> </ul>
Electrolytic capacitor	<ul style="list-style-type: none"> <li>● Whether the electrolytic capacitor has leakage, discoloration, cracks, and whether the safety valve leaks, expands, or ruptures</li> </ul>	<ul style="list-style-type: none"> <li>● Replace defective components</li> </ul>
Circuit board	<ul style="list-style-type: none"> <li>● Whether there is peculiar smell, discoloration, serious rust, and whether the connector connection is correct and reliable</li> </ul>	<ul style="list-style-type: none"> <li>● Fastener connection</li> <li>● Clean the circuit board</li> <li>● Replace damaged circuit board</li> </ul>
Keyboard	<ul style="list-style-type: none"> <li>● Whether the keyboard is damaged and the display is incomplete</li> </ul>	<ul style="list-style-type: none"> <li>● Replace damaged circuit board</li> </ul>



**ATTENTION**

Do not perform related operations when the power is turned on, otherwise there is a danger of electric shock and death. Please make sure power supply of the drive has been cut off, and DC bus voltage has been discharged to 0V prior to maintenance. Never leave screws, gaskets, conductors, tools and other metal articles inside the drive. Failure to comply may result in equipment damage. Never modify the interior components of the drive in any condition. Failure to comply may result in equipment damage.

**7.3 Replacement of Vulnerable Parts**

Vulnerable parts of drive include cooling fan, electrolytic capacitor. The service lives of these parts are subject to environment and working conditions. To maintain a favorable operating environment is conducive to improving the service life of parts and components; routine inspection and maintenance also contributes to effective improvement of parts' service life. To prolong the service life of entire drive, the cooling fan, electrolytic capacitor or other vulnerable parts should be subjected to routine inspection according to the table below. Please replace the abnormal parts (if any) in time.



**ATTENTION**

- Normally, the cooling fan of the drive should be replaced every 2 to 3 years;
- Under normal circumstances, the large-capacity electrolytic capacitor of the drive should be replaced every 4 to 5 years;

**7.4 Storage**

When the inverter is not used temporarily or stored for a long time after purchase, the following matters should be paid attention to:



**ATTENTION**

- Avoid storing the drive in a place with high temperature, humidity or vibration and metal dust, and ensure that the storage place is well ventilated;
- If the drive has not been put into use for a long time, the internal filter capacitor characteristics will decline;
- If the driver is not used for a long time, it should be powered on once every two years to restore the characteristics of the large-capacity filter capacitor, and the function of the driver should be checked at the same time. When energized, the voltage should be gradually increased through an autotransformer, and the energization time should not be less than 5 hours.

# Appendix: Modbus Communication Protocol

FG210series of AC drives can provide RS232/RS485 communication interface, and use MODBUS communication protocol. The user can realize the central control through computer or PLC. Also it can set the running commands, modify or read the function code parameter, read the working status and fault information of the AC drive according to the protocol.

**RTU frame format:**

Frame Header START	3.5 characters time
Slave Address ADR	Contact address:0~247
The command code CMD	03:Read the parameter of the slave machine 06:Write the parameters of the slave machine
The content of the data DATA(N-1)	The content of the DATA: The address of function code parameters; The quantity of function code parameters; The value of function code parameters;
The content of the data DATA(N-2)	
.....	
The content of the data DATA0	
CRC CHK Low order	detection value:CRC16 verified value. low byte is sent previous than High byte.
CRC CHK High order	
End	3.5-characters time

**1. The Definition of Communication Parameter Address**

This part is the content about communication, which used for controlling the running and working status of the frequency convert, and set relevant parameter.

Parameter of read and write function code (some function code can't be changed, only for supplier and monitor usage)

**Labeling rule of function code address:**

Use the group number and mark number of the function code as parameter address rule:  
The high bytes:F0~FF (group F)、B0~BF (group A)、70~7F (group U) the low byte:00~FF  
For example:F0-11, the address indicated as F00B;

**Attention:**

Group FF:The parameter can neither be read nor be altered.  
Group U:The parameter can only be read, but not be altered.

## FG210 User Manual

Some parameter can't be changed when the frequency convert is on running status; some parameter can't be changed regardless of any status of the frequency convert; please pay attention to the range, unit and relevant instruction when changing the function code parameter.

Group number of function code	access address of communication	Function code address of communication revise the RAM
Group F0~FE	0xF000~0xFEFE	0x0000~0x0EFE
Group A0~AF	0xB000~0xBFFF	0x5000~0x5FFF
Group U0、U1	0x70xx、0x71xx	

Pay attention that if the EEPROM is stored continuously, the service life will be reduced. So there is no need to store some function code on the communication mode, just need to change the value in RAM.

If it's group F of the parameter to realize this function, just need to change high byte from F to 0 on the function code address.

If it's group A of the parameter to realize this function, just need to change high byte from B to 5 on the function code address.

The relevant function code address indicated as below:High byte: 00~0F (group F)、50~5F (group A) the low byte: 00~FF

For example: function code F0-11 doesn't store in EEPROM, the address indicated as 000B; this address means that it only can write RAM, but can't use the read action, if it's being read, the address is ineffective.

### Stop / Run Parameter

Parameter Address (HEX)	Parameter Description
0x1000/9000	1000:*Communication set value(-1000~1000) (decimal) (readable and writable) (minimum unit:0.01%),Read/Write
	9000:range(0Hz~F0-10) (minimum unit:0.01Hz), Read/Write
0x1001	Set frequency (minimum unit:0.01Hz), Read-only
0x1002	Running frequency (minimum unit:0.01Hz), Read-only
0x1003	Busbar voltage (minimum unit:0.01V), Read-only
0x1004	Output voltage (minimum unit:0.1V), Read-only
0x1005	Output current (minimum unit:0.1A), Read-only
0x1006	Output power (minimum unit:0.1kw), Read-only
0x1007	DI input flag (minimum unit:1), Read-only
0x1008	DO output flag (minimum unit:1), Read-only
0x1009	PID set (minimum unit:1), Read-only
0x100A	PID feedback (minimum unit:1), Read-only
0x100B	AI1 voltage (minimum unit:0.01V), Read-only
0x100C	Reserved



0x100D	AO1 output voltage (minimum unit:0.01V) , Read-only
0x100E	PLC step (minimum unit:1) , Read-only
0x100F	Rotate speed (minimum unit:1rpm) , Read-only
0x1010	Count value input (minimum unit:1) , Read-only
0x1011	Pulse frequency input (minimum unit:0.01kHz) , Read-only
0x1012	Feedback speed (minimum unit:0.1Hz) , Read-only
0x1013	The remaining run time (minimum unit:0.1 min) , Read-only
0x1014	Voltage before AI1 revised (minimum unit:0.001V) , Read-only
0x1015	Reserved
0x1016	The actual linear speed (minimum unit:1m/min) , Read-only
0x1017	Load speed (minimum unit:user-defined) , Read-only
0x1018	present power-on time (minimum unit:1min) , Read-only
0x1019	Present run time (minimum unit:0.1min) , Read-only
0x101A	Pulse frequency input (minimum unit:1Hz) , Read-only
0x101B	Main frequency X display (minimum unit:0.01Hz) , Read-only
0x101C	Auxiliary frequency Y display (minimum unit:0.01Hz) , Read-only
0x101D	Target torque (minimum unit:0.1%) , regard motor rated torque as 100%, Read-only
0x101E	Output torque (minimum unit:0.1%) , regard motor rated torque as 100%, Read-only
0x101F	Output torque (minimum unit:0.1%) , regard inverter rated current as 100%, Read-only
0x1020	Upper limit torque (minimum unit:0.1%) , regard inverter rated current as 100%, Read-only
0x1021	VF separate target voltage (minimum unit:1V) , Read-only
0x1022	VF separate output voltage (minimum unit:1V) , Read-only
0x1023	Reserved, Read-only
0x1024	Reserved
0x1025	Length value input (minimum unit:1) , Read-only
0x1026	Reserved
0x1027	Status of the invert (minimum unit:1) , Read-only
0x1028	Present malfunction (minimum unit:1) , Read-only

**Example 1:** read the run frequency of the first machine: 0x01 0x03 0x10 0x02 0x00  
 0x01 0x21 0x0A 0x10 0x02 (1002) run frequency address, 0x00 0x01 (0001) one data

## FG210 User Manual

---

0x21 0x0a (0A21) CRC verified value.

**Example 2:** read the busbar voltage, output voltage, output current of the first machine at the same time: 0x01 0x03 0x10 0x03 0x00 0x03 CRC verified value, the meaning of the data is similar to example 1.

**Attention:**

Communication set value is a relative percentage value, 10000 correspond to 100.00% and -10000 correspond to -100.00%

For the data of frequency dimension, this percentage is the percentage of the relative maximum frequency (F0-12); for the data of torque, this percentage is F3-17, F3-19, L2-17, L2-19.

**Control command input to the frequency convert: (Write only)**

Command word address (HEX)	Command word function
0x2000	0001:Forward operation
	0002:Reverse operation
	0003:Forward jog
	0004:Reverse jog
	0005:Free stop
	0006:Slow-down stop
	0007:Fault reset
	0008:Fault reset (only in communication control mode can be fault reset)

**Example 3:** give command forward rotating to the second machine: 0x02 0x06 0x20 0x00 0x00 0x01 CRC verified value

**Read the status of the frequency convert:(read only)**

Status word address (HEX)	Status word function
0x3000	0001:Forward operation
	0002:Reverse operation
	0003:Stop

**Digital output terminal control:(write only)**

Command address (HEX)	Command content
0x2001	BIT0:RELAY1 output control BIT1:RELAY2 output control BIT2:DO1 output control BIT3:Reserved BIT4:Reserved

**Attention:**D0 output terminal need to choose 16 (communication control) function.

**Analog AO1 control:(write only)**

Command address (HEX)	Command content
0x2002	0~7FFF represent 0%~100%

**Analog AO2 control:(write only)**

Command address (HEX)	Command content
0x2003	0~7FFF represent 0%~100%

**Attention:**AO output need to choose 7 (communication control output) function.

**Fault descriptions of the frequency convert:**

The fault address (HEX)	The fault detail information
0x8000	0000:No fault 0001:Inverter unit protection 0002:Overcurrent during acceleration 0003:Overcurrent during deceleration 0004:Over current at constant speed 0008:Overvoltage during acceleration 0009:Overvoltage during deceleration 000A:Overvoltage at constant speed 000B:Under voltage 000C:Power input phase loss 000D:Power output phase loss 000E:Drive overload 000F:Motor overload 0010:Current detection fault 0011:Drive overheat 0012:Load becoming 0 0013:Too large speed deviation 0014:Short circuit to ground 0015:External equipment fault 0016:Fast current limit fault 0017:Communication fault 0018:Master slave control communication disconnection 0019:EEPROM read-write fault 001A:PID feedback lost during running 001B:EEPROM storage fault 001C:Control power supply fault 001D:Motor switchover error during running 001E:Current running time reached 001F:Accumulative running time reached 0020:Motor auto-tuning fault 0021:Motor over-speed 0031:User-definedfault 1 0032:User-definedfault 2